

Series TSW 210-310

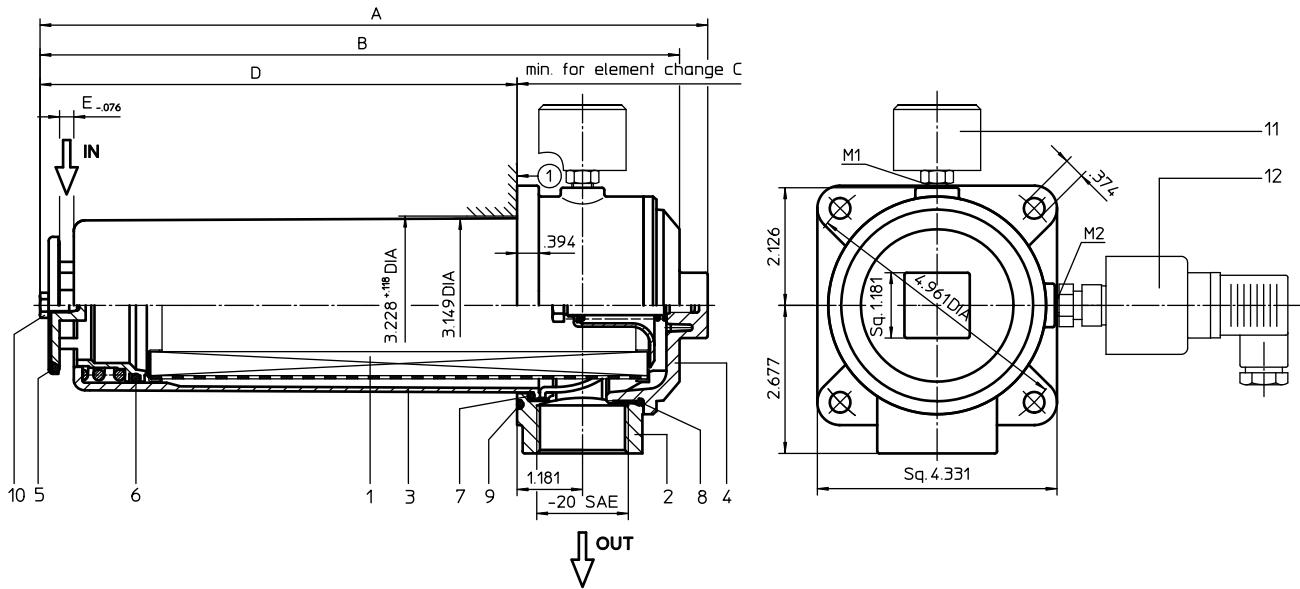

Dimensions:

type	TSW 210	TSW 310
connection	- 20 SAE	-20 SAE
A	12.09	15.47
B	11.57	14.96
C	11.42	14.76
D	8.62	12.00
E	.26	.30
weight	5.10 lbs.	6.60 lbs.
volume tank	.30 Gal.	.40 Gal.

- mounting surface 1
- surface quality .12 μ in
▽
- flatness tolerance \square .01"

Dimensions: inches

Designs and performance values are subject to change.

Suction Filter

Series TSW 210-310

Description:

The TSW filters are directly mounted to the reservoir and connected to the suction-line.

The filter element consists of star-shaped, pleated filter material, which is supported on the inside by a perforated core tube and is bonded to the end caps with a high-quality adhesive. The flow direction is from outside to inside.

Eaton filter elements are known for a high intrinsic stability and an excellent filtration capability, a high dirt-retaining capacity and a long service life.

For filtration finer than 40 µm use the disposable elements made of microglass. Filter elements as fine as 5 µm(c) are available; finer filter elements on request.

Eaton filter elements can be used for petroleum-based fluids, HW emulsions, water glycols, most synthetic fluids and lubrication fluids. Consult factory for specific fluid applications.

When removing the filter cover, a plate-shaped valve closes the suction-inlet of the filter bowl and prevents dirty oil from flowing into the tank. For cleaning, the filter bowl and the filter element can be taken out of the filter head.

1. Type index:

1.1. Complete filter: (ordering example)

TSW. 210. 10VG. - . B. P. - . UG. 6. - . - . O1. E4												
1	2	3	4	5	6	7	8	9	10	11	12	13

- 1 series:**
TSW = suction filter for horizontal tank-mounting
- 2 nominal size:** 210, 310
- 3 filter-material and filter-fineness:**
80G, 40G, 25G stainless steel wire mesh
25VG, 16VG, 10VG, 6VG, 3VG microglass
10P paper
- 4 filter element collapse rating:**
- = not specified
- 5 filter element design:**
B = both sides open
- 6 sealing material:**
P = Nitrile (NBR)
V = Viton (FPM)
- 7 filter element specification:**
- = standard
VA = stainless steel
- 8 process connection:**
UG = thread connection
- 9 process connection size:**
6 = -20 SAE
- 10 filter housing specification:**
- = standard
- 11 internal valve:**
- = without
S = with by-pass valve Δp 4.1 PSI
- 12 clogging indicator at M1:**
- = without
O1 = visual, see sheet-no. 1616
E4 = pressure switch, see sheet-no. 1616
- 13 clogging indicator at M2:**
possible indicators see position 12 of the type index

To add an indicator to your filter, use the corresponding indicator data sheet to find the indicator details and add them to the filter assembly model code.

1.2. Filter element: (ordering example)

01TS. 210. 10VG. - . B. - . -						
1	2	3	4	5	6	7

- 1 series:**
01TS. = suction filter element according to company standard
- 2 nominal size:** 210, 310
- 3 - 5 / 7** see type index-complete filter
- 6 seling material:**
- = without

Technical data:

design temperature:	14 °F to +212 °F
operating temperature:	14 °F to +176 °F
operating medium	mineral oil, other media on request
process connection:	thread connection
housing material:	Al-casting, glass fiber reinforced polyamide
sealing material:	Nitrile (NBR) or Viton (FPM), other materials on request
installation position:	vertical

Classified under the Pressure Equipment Directive 2014/68/EC for mineral oil (fluid group 2), Article 4, Para. 3.
 Classified under ATEX Directive 2014/34/EC according to specific application (see questionnaire sheet-no. 34279-4).

Pressure drop flow curves:

Filter calculation/sizing

The pressure drop of the assembly at a given flow rate Q is the sum of the housing Δp and the element Δp and is calculated as follows:

$$\Delta p_{assembly} = \Delta p_{housing} + \Delta p_{element}$$

$$\Delta p_{housing} = (\text{see } \Delta p = f(Q) \text{ - characteristics})$$

$$\Delta p_{element} (PSI) = Q (GPM) \times \frac{MSK}{1000} \left(\frac{PSI}{GPM} \right) \times \nu (SUS) \times \frac{\rho}{0.876} \left(\frac{kg}{dm^3} \right)$$

For ease of calculation our Filter Selection tool is available online at www.eatonpowersource.com/calculators/filtration/

Material gradient coefficients (MSK) for filter elements

The material gradient coefficients in psi/gpm apply to mineral oil (HLP) with a density of 0.876 kg/dm³ and a kinematic viscosity of 139 SUS (30 mm²/s). The pressure drop changes proportionally to the change in kinematic viscosity and density.

TSW	VG					G			P
	3VG	6VG	10VG	16VG	25VG	25G	40G	80G	10P
210	2.250	1.562	1.000	0.871	0.595	0.0826	0.0612	0.0571	0.443
310	1.628	1.130	0.724	0.630	0.430	0.0598	0.0443	0.0413	0.321

$\Delta p = f(Q)$ – characteristics according to ISO 3968

The pressure drop characteristics apply to mineral oil (HLP) with a density of 0.876 kg/dm³. The pressure drop changes proportionally to the density.

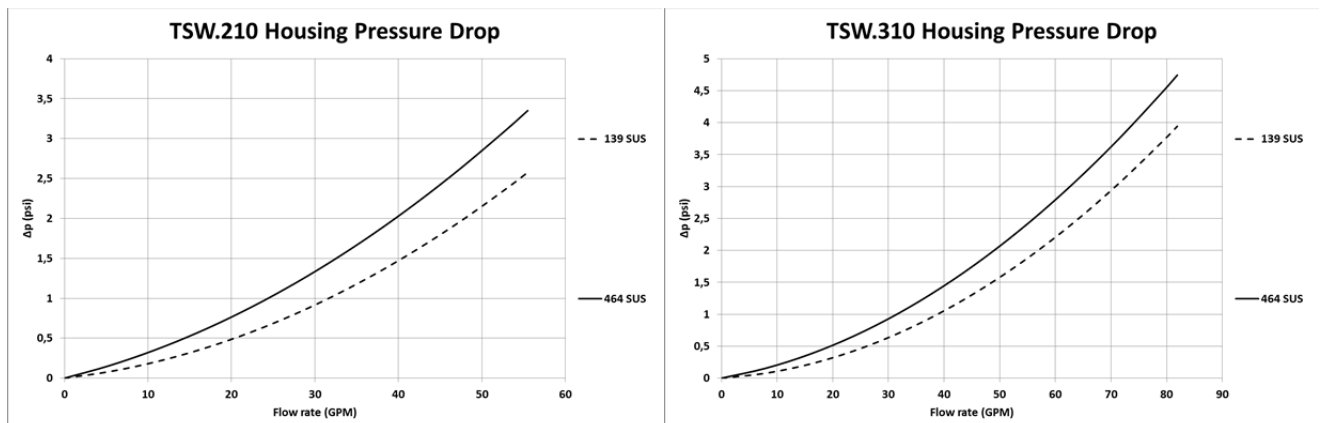

Symbols:

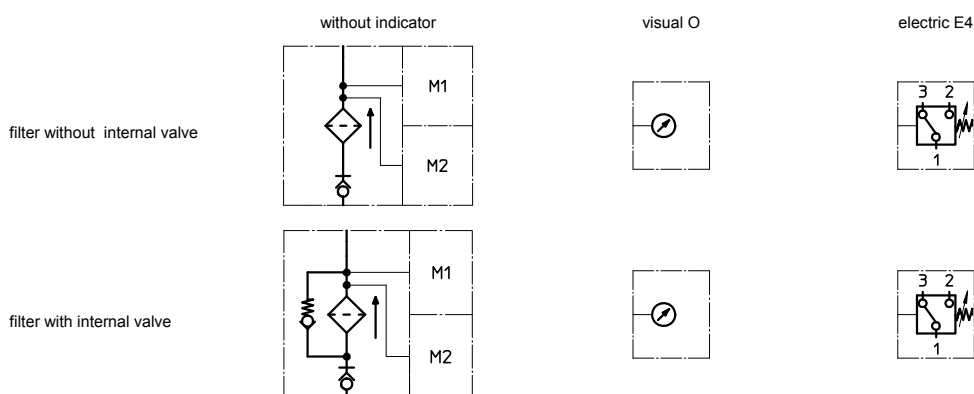

Spare parts:

item	qty.	designation	dimension		article-no.	
			TSW 210	TSW 310		
1	1	filter element	01TS.210...	01TS.310...		
2	1	filter head			304423	
3	1	filter bowl			304518.1	
4	1	filter cover	M 90 x 2			
5	1	O-ring	53 x 4		309143 (NBR)	332434 (FPM)
6	1	O-ring	62 x 4		308045 (NBR)	311472 (FPM)
7	1	O-ring	75 x 3		302215 (NBR)	304729 (FPM)
8	1	O-ring	82 x 3		305191 (NBR)	305298 (FPM)
9	1	O-ring	88 x 3		304417 (NBR)	310266 (FPM)
10	1	sheet metal screw	B 6,3 x 13		316641	
11	1	clogging indicator, visual	O1		301722	
12	1	pressure switch, electric	E4		311016	

Test methods:

Filter elements are tested according to the following ISO standards:

ISO 2941	Verification of collapse/burst resistance
ISO 2942	Verification of fabrication integrity
ISO 2943	Verification of material compatibility with fluids
ISO 3723	Method for end load test
ISO 3724	Verification of flow fatigue characteristics
ISO 3968	Evaluation of pressure drop versus flow characteristics
ISO 16889	Multi-pass method for evaluating filtration performance

SUCTION FILTER, for horizontal tank-mounting

Series TSW 426

Sheet No.
1906 E

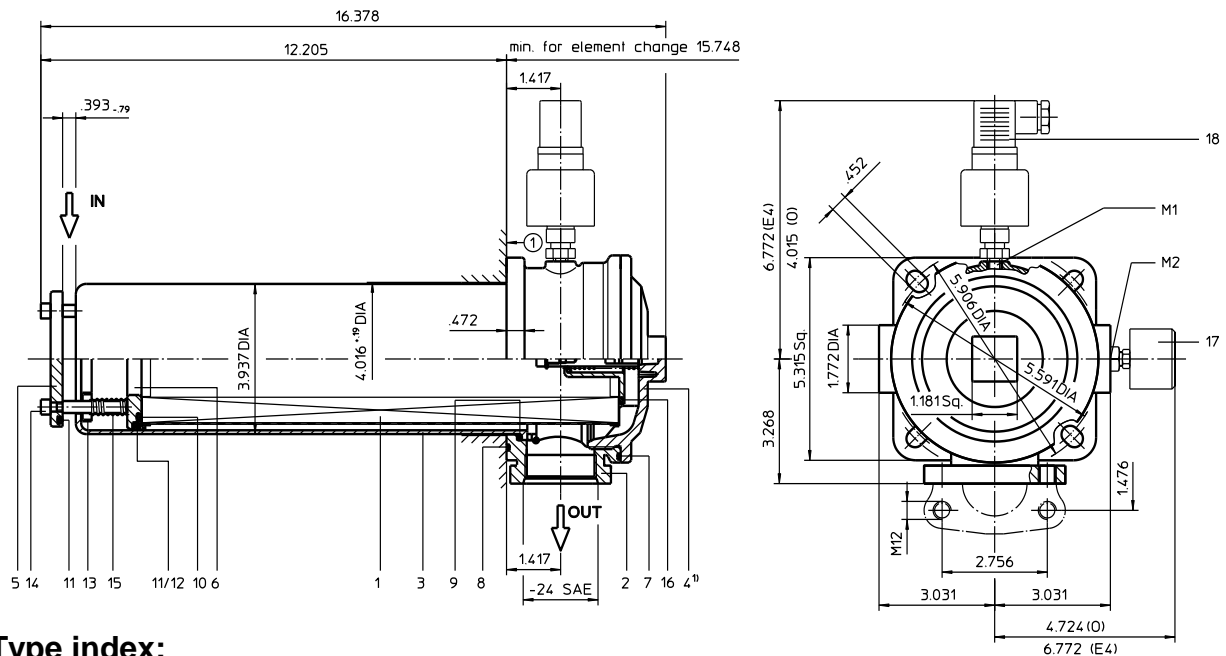

1. Type index:

1.1. Complete filter: (ordering example)

TSW.426.10VG. -. B. P. -. UG. 7. -. -. E4. O1

1	2	3	4	5	6	7	8	9	10	11	12	13
---	---	---	---	---	---	---	---	---	----	----	----	----

- 1 series:**
TSW = suction filter for horizontal tank-mounting
- 2 nominal size:** 426
- 3 filter-material and filter-fineness:**
80 G = 80 μm , 40 G = 40 μm ,
25 G = 25 μm stainless steel wire mesh
25 VG = 25 $\mu\text{m}_{(c)}$, 16 VG = 15 $\mu\text{m}_{(c)}$, 10 VG = 10 $\mu\text{m}_{(c)}$,
6 VG = 7 $\mu\text{m}_{(c)}$, 3 VG = 5 $\mu\text{m}_{(c)}$ Interpor fleece (glass fiber)
10 P = 10 μm paper
- 4 resistance of pressure difference for filter element:**
- = not specified
- 5 filter element design:**
B = both sides open
- 6 sealing material:**
P = Nitrile (NBR); V = Viton (FPM)
- 7 filter element specification:**
- = standard; VA = stainless steel
- 8 connection:**
UG = thread connection
FS = SAE-flange connection 3000 PSI
- 9 connection size:**
7 = -24 SAE or 1 1/2" SAE
- 10 filter element specification:**
- = standard
- 11 internal valve:**
- = without; S = with by-pass valve Δp 4.1 PSI
- 12 clogging indicator at M1:**
- = without
O1 = visual, see sheet-no. 1616
E4 = pressure switch, see sheet-no. 1616
- 13 clogging indicator at M2:**
possible indicators see position 12 of the type index

1.2. Filter element: (ordering example)

01TS.425.10VG. -. B. -. -

1	2	3	4	5	6	7
---	---	---	---	---	---	---

- 1 series:**
01TS. = suction filter element according to company standard
- 2 nominal size:** 425
- 3 - 5 , 7** see type index complete filter
- 6 sealing material:**
- = without

- mounting surface 1
- surface quality $.12 \mu\text{in}$
- flatness tolerance .01"

¹⁾ The by-pass valve is integrated in the screw plug. For the filter without a by-pass-valve the opening function is raised up to $\Delta p > 14.5$ PSI.

weight: 12.5 lbs.

2. Spare parts:

item	qty.	designation	dimension	article-no.	
1	1	filter element	01TS. 425		
2	1	filter head	NG 426		
3	1	filter bowl	NG 426	303732	
4	1	screw plug with by-pass	M 120 x 3	313455	
	1	screw plug without by-pass	M 120 x 3	313649	
5	1	valve disc		311892	
6	1	valve bushing		307548	
7	1	O-ring	128 x 3	304602 (NBR)	308140 (FPM)
8	1	O-ring	115 x 3	303963 (NBR)	307762 (FPM)
9	1	O-ring	98 x 4	301914 (NBR)	304765 (FPM)
10	1	O-ring	70 x 4	306253 (NBR)	310280 (FPM)
11	2	O-ring	76 x 4	305599 (NBR)	310291 (FPM)
12	1	sliding ring		307547	
13	1	pressure ring		307549	
14	1	fillister head cap screw	M 6 x 60	307534	
15	1	spring	1,6 x 10 x 53	311847	
16	1	O-ring	50 x 3	307398 (NBR)	314682 (FPM)
17	1	clogging indicator, visual	O1	301722	
18	1	clogging indicator, electrical	E4	311016	

3. Description:

The TSW-filters are directly mounted to the reservoir and connected to the suction-line. The filter element consists of a star-shaped, pleated filter material which is supported on the inside by a perforated core tube and is bonded to the end caps with a high-quality adhesive. The flow is from inside to outside. Filters finer than 40 µm should use throw-away elements made of paper or Interpor fleece (VG). Filter elements as fine as 5 µm_(c) are available; finer filter elements on request.

Internormen Product Line filter elements are known as elements with a high intrinsic stability and an excellent filtration capability, a high dirt-retaining capacity and a long service life.

Internormen Product Line filters are suitable for all petroleum based fluids, HW-emulsions, most synthetic hydraulic fluids and lubrication oils.

Due to its practical design, the return-line filter is easy to service. When releasing the filter cover a plate-shaped valve closes the suction-inlet of the filter bowl and prevents leakage of fluid out of the tank. Filter element can be removed from filter pot for cleaning purposes.

4. Technical data:

temperature range:
operating medium:
connection system:
housing material:
sealing material:
installation position:
volume tank:

+14°F to +80°F (for a short time + 212°F)
mineral oil, other media on request
thread connection or SAE-flange connection 3000 PSI
Al-casting; glass fibre reinforced polyamide
Nitrile (NBR) or Viton (FPM), other materials on request
horizontal
.70 Gal.

Classified under the Pressure Equipment Directive 97/23/EC for mineral oil (fluid group 2), Article 3, Para. 3.
Classified under ATEX Directive 94/9/EC according to specific application (see questionnaire sheet-no. 34279-4).

5. Symbols:

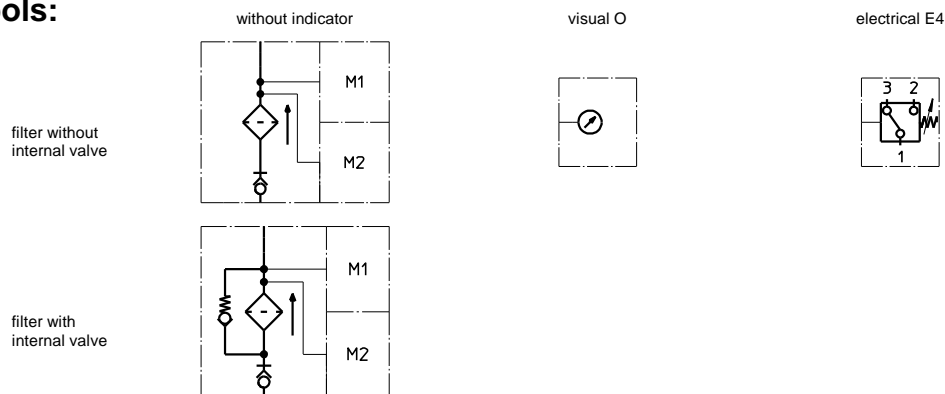

6. Pressure drop flow curves:

Precise flow rates see 'Interactive Product Specifier' respectively Δp -curves; depending on filter fineness and viscosity.

7. Test methods:

Filter elements are tested according to the following ISO standards:

- ISO 2941 Verification of collapse/burst resistance
- ISO 2942 Verification of fabrication integrity
- ISO 2943 Verification of material compatibility with fluids
- ISO 3723 Method for end load test
- ISO 3724 Verification of flow fatigue characteristics
- ISO 3968 Evaluation of pressure drop versus flow characteristics
- ISO 16889 Multi-pass method for evaluating filtration performance

SUCTION FILTER, for horizontal tank-mounting

Series TSW 625

Sheet No.
1911 D

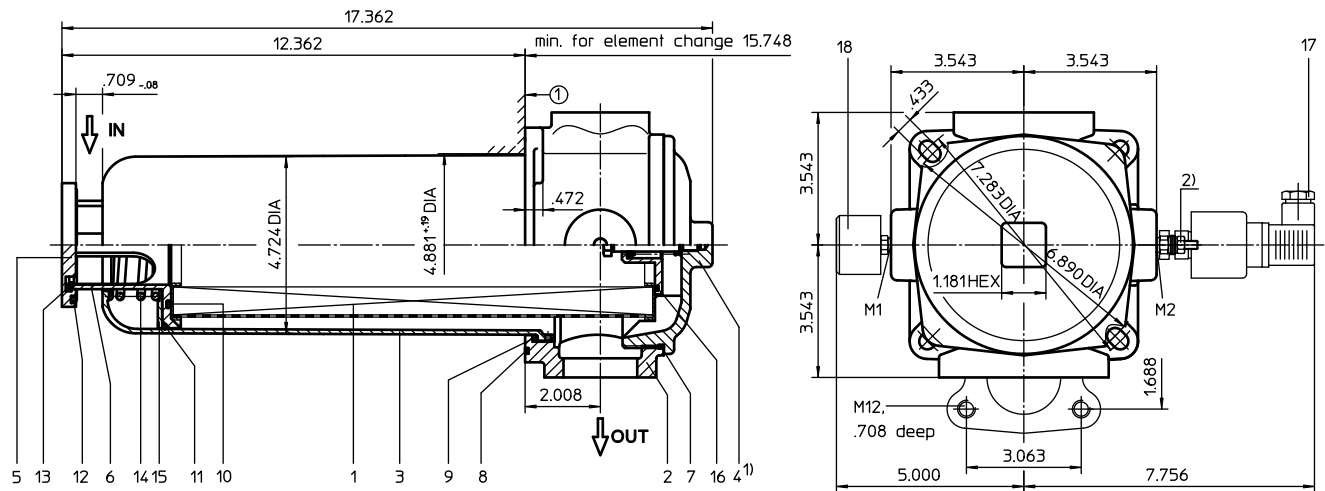

1. Type index:

1.1. Complete filter: (ordering example)

TSW. 625. 10VG. -. B. P. -. FS. 8. -. -. O1. E4

1	2	3	4	5	6	7	8	9	10	11	12	13
---	---	---	---	---	---	---	---	---	----	----	----	----

- 1 **series:**
TSW = suction filter for horizontal tank-mounting
- 2 **nominal size:** 625
- 3 **filter-material and filter-fineness:**
80 G = 80 μm , 40 G = 40 μm ,
25 G = 25 μm stainless steel wire mesh
25 VG = 20 $\mu\text{m}_{(c)}$, 16 VG = 15 $\mu\text{m}_{(c)}$, 10 VG = 10 $\mu\text{m}_{(c)}$,
6 VG = 7 $\mu\text{m}_{(c)}$, 3 VG = 5 $\mu\text{m}_{(c)}$ Interpor fleece (glass fiber)
10 P = 10 μm paper
- 4 **resistance of pressure difference for filter element:**
- = not specified
- 5 **filter element design:**
B = both sides open
- 6 **sealing material:**
P = Nitrile (NBR)
V = Viton (FPM)
- 7 **filter element specification:**
- = standard
VA = stainless steel
- 8 **connection:**
FS = SAE-flange connection 3000 PSI
- 9 **connection size:**
8 = 2"
- 10 **filter element specification:**
- = standard
IS11 = see sheet-no. 40530
- 11 **internal valve:**
- = without;
S = with by-pass valve Δp 4.1 PSI
- 12 **measure connection at M1:**
- = without
O1 = visual, see sheet-no. 1616
E4 = pressure switch, see sheet-no. 1616
PA = potential equalisation
- 13 **measure connection at M2:**
possible indicators see position 12 of the type index

1.2. Filter element: (ordering example)

01TS. 625. 10VG. -. B. -. -

1	2	3	4	5	6	7
---	---	---	---	---	---	---

- 1 **series:**
01TS. = suction filter element according to company standard
- 2 **nominal size:** 625
- 3 - 5, 7 see type index complete filter
- 6 **sealing material:**
- = without

mounting surface 1

surface quality $.12 \mu\text{in}$

flatness tolerance \square .01"

1) The by-pass valve is integrated in the screw plug. For the filter without a by-pass-valve the opening function is raised up to $\Delta p > 14.5$ PSI.

2) Connection for the potential equalisation, only for application in the explosive area.

weight: approx. 12 lbs.

2. Spare parts:

item	qty.	designation	dimension	article-no.	
1	1	filter element	01TS.625		
2	1	filter head	NG 625		
3	1	filter bowl	NG 625		
4	1	screw plug with by-pass valve	M 140 x 3		
	1	screw plug without by-pass valve	M 140 x 3		
5	1	valve disc		318740	
6	1	valve bushing		318739	
7	1	O-ring	135 x 3,5	318386 (NBR)	318387 (FPM)
8	1	O-ring	140 x 3	304604 (NBR)	307514 (FPM)
9	1	O-ring	120 x 4	305300 (NBR)	307991 (FPM)
10	1	O-ring	76 x 4	305599 (NBR)	310291 (FPM)
11	1	O-ring	104,37 x 3,53	304339 (NBR)	304390 (FPM)
12	1	O-ring	70 x 4	306253 (NBR)	310280 (FPM)
13	1	snap ring	B 55	311976	
14	1	spring	5,0 x 70 x 117 x 3,5	318742	
15	1	disc		318741	
16	1	O-ring	56 x 3	307398 (NBR)	314682 (FPM)
17	1	clogging indicator, visual	E4	311016	
18	1	clogging indicator, electrical	O1	301722	

3. Description:

The TSW-filters are directly mounted to the reservoir and connected to the suction-line. The filter element consists of a star-shaped, pleated filter material which is supported on the inside by a perforated core tube and is bonded to the end caps with a high-quality adhesive. The flow is from inside to outside. Filters finer than 40 µm should use throw-away elements made of paper or Interpor fleece (VG). Filter elements as fine as 5 µm_(c) are available; finer filter elements on request.

Internormen Product Line filter elements are known as elements with a high intrinsic stability and an excellent filtration capability, a high dirt-retaining capacity and a long service life.

Internormen Product Line filters are suitable for all petroleum based fluids, HW-emulsions, most synthetic hydraulic fluids and lubrication oils.

Due to its practical design, the return-line filter is easy to service. When releasing the filter cover a plate-shaped valve closes the suction-inlet of the filter bowl and prevents leakage of fluid out of the tank. Filter element can be removed from filter pot for cleaning purposes.

4. Technical data:

temperature range:	+ 14°F to + 176°F (for a short time + 212°F)
operating medium:	mineral oil, other media on request
connection system:	SAE-flange connection 3000 PSI
housing material:	filter head / screw plug AL, filter bowl glass fiber reinforced polyamide (standard) filter head / screw plug GG, filter bowl carbon fiber reinforced polyamide (IS11)
sealing material:	Nitrile (NBR) or Viton (FPM), other materials on request
installation position:	horizontal
volume tank:	1.0 Gal.

Classified under the Pressure Equipment Directive 97/23/EC for mineral oil (fluid group 2), Article 3, Para. 3.

Classified under ATEX Directive 94/9/EC according to specific application (see questionnaire sheet-no. 34279-4).

5. Symbols:

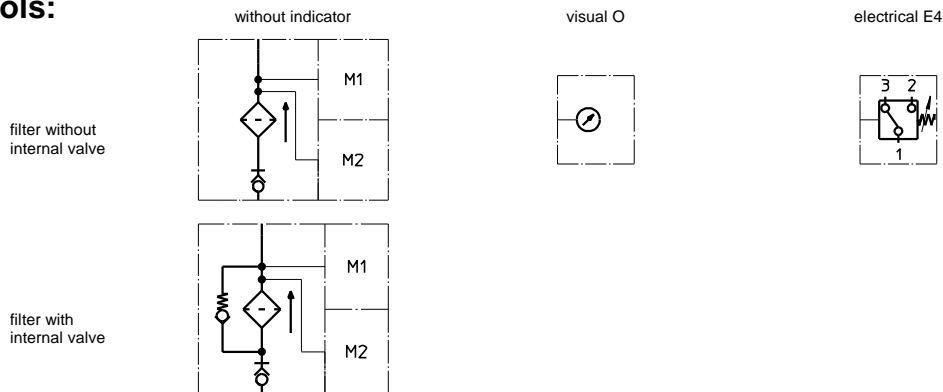

6. Pressure drop flow curves: Precise flow rates see 'Interactive Product Specifier', respectively Δp -curves; depending on filter fineness and viscosity.

7. Test methods:

Filter elements are tested according to the following ISO standards:

ISO 2941	Verification of collapse/burst resistance
ISO 2942	Verification of fabrication integrity
ISO 2943	Verification of material compatibility with fluids
ISO 3723	Method for end load test
ISO 3724	Verification of flow fatigue characteristics
ISO 3968	Evaluation of pressure drop versus flow characteristics
ISO 16889	Multi-pass method for evaluating filtration performance

1. Assembly

The filter is ready to install once it has been removed from the packaging and is placed on a level surface and screwed tightly. Next the protective closures are removed from the connection openings, which must then be connected with the screwed pipe joints of the pipe system.

Attention!

When assembling, it is essential to ensure

- that no dirt, foreign particles or liquids can get into the filter. To do so the complete maintenance process as per item 3 has to be done rapidly. In case of interruption of this process the filter housing has to be closed by means of the screw plug or the filter cover respectively. Both filter and unit concerned have to be marked „Maintenance, not in operation“.
- that the screw-in joint of the pipe system is exactly aligned to the filter connections before screwing commences (screwed pipe joints which are bent or under stress will hamper the connection to the filter and endanger tightness),
- that the filter pot is not lying against the opening, the wall or the floor of the container.

2. Startup

All accessory parts such as the contamination display must be fully installed before startup (power connection). The hydraulic system must be ventilated in accordance with the instructions for the hydraulic components used. After ventilation, the level of liquid in the tank must be above the filter openings "ON" under all operating conditions. The filter is then operational.

3. Maintenance

If the contamination display indicates after the corresponding period of operation that the filter element has reached the limit of its dirt collection capacity, you must replace the filter element as follows:

- Relieve the pressure of the hydraulic system (make sure that the level of fluid is above the level of the filter housing).
- Place collecting basin with capacity of 2 l underneath the screw plug or the filter cover respectively.
- Undo and remove the screw plug or filter lid. (The oil being in the filter pot is flowing into the collecting basin)
- Withdraw the filter element from the filter pot.
- Fit a new or serviced filter element into the filter pot. Only filter elements with a fabric filter material can be cleaned, cf. cleaning instructions sheet no. 21070 and 39448.
- Filter element into the upper part of the filter.
- Fit the screw plug or filter lid into the upper part of the filter and screw tight.

Tightening torques for screw plugs

TSW 210/310	TSW 426	TSW 625
20 Nm	60 Nm	80 Nm

The filter is functional again.

4. Additional information

The filter elements must be exchanged completely, i.e. including their seals. If cleaned filter elements are used repeatedly, their you must replace the seals with new ones.

Worn, damaged or ageing seals on the screw plug or filter pot must be replaced with new seal elements during maintenance.

Refer to the relevant documentation for the filter to obtain the descriptions of the spare parts (filter elements, seal elements etc.).

While the filter is open during maintenance (screw plug removed), you must make sure that no dirt or foreign particles can get into the liquid tank.

To avoid environmental damage, make sure that the remaining fluid from the filter pot and the solvents that are used are disposed of properly after maintenance.

5. Service

The service will be performed by

EATON Technologies GmbH
Friedensstr. 41
D-68804 Altlussheim
Germany

phone: +49(0)6205-2094-0
fax: +49(0)6205-2094-40

Special questions about the operation of the filter will also be answered within this area.

Spare parts respectively wearing parts have to be ordered according to the spare part list of the filter-data-sheet.