

INSTALLATION OPERATION & MAINTENANCE OF DUPLEX BASKET STRAINER

PLEASE READ THE FOLLOWING INFORMATION PRIOR TO INSTALLING AND USING FACTORY DIRECT PIPELINE PRODUCTS VALVES, STRAINERS, FILTERS, AND OTHER ASSOCIATED PRODUCTS. FAILURE TO FOLLOW THESE INSTRUCTIONS MAY RESULT IN SERIOUS INJURY.

1. Factory Direct Pipeline Products guarantees its products against defective material and workmanship only. Factory Direct Pipeline Products assumes no responsibility for damage or injuries resulting from improper installation, misapplication, or abuse of any product.
2. Factory Direct Pipeline Products assumes no responsibility for damage or injury resulting from chemical incompatibility between its products and the process fluids to which they are subjected. Compatibility charts provided in Factory Direct Pipeline Products literature are based on ambient temperatures of 70°F and are for reference only. Customer should always test to determine application suitability.
3. Consult Factory Direct Pipeline Products literature to determine operating pressure and temperature limitations before installing any Factory Direct Pipeline Products product. Note that the maximum recommended fluid velocity through any Factory Direct Pipeline Products product is five feet per second. Higher flow rates can result in possible damage due to the water hammer effect. Also note that maximum operating pressure is dependent upon material selection as well as operating temperature.
4. Factory Direct Pipeline Products strainers are designed primarily for use with non-compressible liquids. They should NEVER be used or tested with compressible fluids such as compressed air or nitrogen.
5. Systems should always be depressurized and drained prior to installing or maintaining Factory Direct Pipeline Products products.
6. Temperature effect on piping systems should always be considered when the systems are initially designed. Piping systems must be designed and supported to prevent excess mechanical loading on Factory Direct Pipeline Products equipment due to system misalignment, weight, shock, vibration, and the effects of thermal expansion and contraction.
7. Because PVC and CPVC plastic products become brittle below 40°F, Factory Direct Pipeline Products recommends caution in their installation and use below this temperature.
8. Published operating torque requirements are based upon testing of new valves using clean water at 70°F. Valve torque is affected by many factors including fluid chemistry, viscosity, flow rate, and temperature. These should be considered when sizing electric or pneumatic actuators.
9. Due to differential thermal expansion rates between metal and plastic, transmittal of pipe vibration, and pipe loading forces DIRECT INSTALLATION OF METAL PIPE INTO PLASTIC CONNECTIONS IS NOT RECOMMENDED. Wherever installation of a plastic duplex strainer into a metal piping systems is necessary, it is recommended that at least 10 pipe diameter in length of plastic pipe be installed upstream and downstream of the plastic duplex strainer to compensate for the factors mentioned above.

- **SOCKET CONNECTION INSTALLATION:**

BOTH THE COVERS OF THE BASKET STRAINERS MUST BE REMOVED TO ALLOW THE CEMENT FUMES TO VENT.

Socket end connections are manufactured to ASTM D2467-94. Solvent cementing of socket end connections to pipe should be performed per ASTM specifications D2855-87. Cut pipe square. Chamfer and deburr pipe. Surfaces must be cleaned and free of dirt, moisture, oil and other foreign material. Apply primer to inside socket surface of the valve on the Duplex strainer. Never allow primer or cement to contact valve ball, as leaking may result. Use a scrubbing motion. Repeat applications may be necessary to soften the surface of the socket. Next, liberally apply primer to the male end of the pipe to the length of the socket depth. Again apply to the socket, without delay apply cement to the pipe while the surface is still wet with primer. Next apply cement lightly, but uniformly to the inside of the socket. Apply a second coat of cement to the pipe, and assemble the pipe to the end socket of the Duplex, rotating the pipe 1/4 turn in one direction as it is slipped to full depth into the socket. The connection should be held in position for approx. 30 seconds to allow the connection to "set". After assembly wipe off excess cement. Full set time is a minimum of 30 minutes at 60 to 100 °F. Full cure time should be based on the chart below.

- **JOINT CURE SCHEDULE:**

The cure schedules are suggested as guides. They are based on laboratory test data, and should not be taken to be the recommendations of all cement manufacturers. Individual manufacturer's recommendations for their particular cement should be followed.

Temperature Range During Cure Period(B) °F(°C)	Test Pressures for Pipe Sizes ½" to 1-1/4"		Test Pressures for Pipe Sizes 1-1/2" to 3"		Test Pressures for Pipe Sizes 4" & 5"		Test Pressures for Pipe Sizes 6" to 8"	
	Up to 180 PSI (1240 kPa)	Above 180 to 370 PSI (1240 to 2550 kPa)	Up to 180 PSI (1240 kPa)	Above 180 to 315 PSI (1240 to 2172 kPa)	Up to 180 PSI (1240 kPa)	Above 180 to 315 PSI (1240 to 2172 kPa)	Up to 180 PSI (1240 kPa)	Above 180 to 315 PSI (1240 to 2172 kPa)
60 to 100 (15 to 40)	1 hour	6 hours	2 hours	12 hours	6 hours	18 hours	8 hours	1 day
40 to 60 (5 to 15)	2 hours	12 hours	4 hours	1 day	12 hours	36 hours	16 hours	4 days
20 to 40 (-7 to 5)	6 hours	36 hours	12 hours	3 days	36 hours (A)	4 days (A)	3 days (A)	9 days (A)
10 to 20 (-15 to 7)	8 hours	2 days	16 hours	4 days	3 days (A)	8 days (A)	4 days (A)	12 days (A)

Colder than 10 (-15) Extreme care should be exercised on all joints made where pipe, fittings or cement is below 10°F.

A: It is important to note that at temperatures colder than 20°F on sizes that exceed 3 in., test results indicate that many variables exist in the actual cure rate of the joint. The data expressed in these categories represent only estimated averages. In some cases, cure will be achieved in less time, but isolated test results indicate that even longer periods of cure may be required.

B: These cure schedules are based on laboratory test data obtained on Net Fit Joints (NET FIT=in a dry fit the pipe bottoms snugly in the fitting socket without meeting interference).

- **THREADED CONNECTION INSTALLATION:**

Threaded end connections are manufactured to ASTM specifications D2464-88, F437-88 and ANSI B2.1. Wrap threads of pipe with Teflon tape of 3 to 3-1/2 mil thickness. The tape should be wrapped in a clockwise direction starting at the first or second full thread. Overlap each wrap by, 1/2 the width of the tape. The wrap should be applied with sufficient tension to allow the threads of a single wrapped area to show through without cutting the tape. The wrap should continue for the full effective length of the thread. Pipe sizes 2" and greater will not benefit with more than a second wrap, due to the greater thread depth. To provide a leak proof joint, the pipe should be threaded into the end connection "hand tight". Using a strap wrench only. (Never use a stillson type wrench) tighten the joint an additional 1/2 to 1-1/2 turns past hand tight. Tightening beyond this point may induce excessive stress that could cause failure.

- **FLANGED CONNECTION INSTALLATION:**

Flange bolts should be tight enough to slightly compress the gasket and make a good seal, without distorting or putting excessive stress on the flanges. Suitable washers should be used between the bolt head and flange and the nut and flange. Bolts should be tightened in alternating sequence.

RECOMMENDED FLANGE BOLT TORQUE

FLANGE SIZE	BOLT DIA.	TORQUE FT. LBS.	FLANGE SIZE	BOLT DIA.	TORQUE FT. LBS.
1/2	1/2	10-15	2	5/8	15-25
3/4	1/2	10-15	2-1/2	5/8	20-25
1	1/2	10-15	3	5/8	20-25
1-1/4	1/2	10-15	4	5/8	20-25
1-1/2	1/2	10-15	6	3/4	30-40

NOTE: USE WELL LUBRICATED METAL BOLTS AND NUTS. USE SOFT RUBBER GASKETS.

- **METAL PIPING INSTALLATION:**

Due to different thermal expansion rates between metal and plastic, transmittal of pipe vibration, and pipe loading forces, direct installation of plastic duplex strainers into metal piping systems can potentially damage the duplex strainer.

IT IS RECOMMENDED THAT AT LEAST 10 PIPE DIAMETERS IN LENGTH OF PLASTIC PIPING BE INSTALLED UPSTREAM AND DOWNSTREAM OF THE DUPLEX STRAINER.

- **OPERATION and BASKET CLEANING:**

CAUTION: Only the strainer that the lever is not touching is off line and must be depressurized before proceeding further.

Both covers must be installed per Step 5 below on the strainers before the lever is moved.

Serious injury or death due to chemical or liquid spray can result if the lever is moved when a cover is off or not fully seated.



The maximum recommended fluid velocity is 5 feet per second. Lower fluid velocity minimizes the effects of valve closure and pump start up or shut down.

Pressure gauges may be installed on the inlet and the outlet piping to indicate by pressure loss, in excess of 5 psi, when the active basket should be cleaned.

1. The lever position indicates which is the active strainer. By being positioned toward a given strainer, the opposite strainer can be serviced. When a basket is to be removed from a strainer for cleaning the **LEVER** must be moved **SLOWLY** from one position to the other.
2. The drain plug, from the strainer that has been taken off line for servicing, should carefully be removed to depressurize and partially drain the strainer. The vent plug can be carefully loosened to aid in draining the vessel.
3. The off line strainer cover is removed by turning in a counter-clockwise direction. No tools are required. *Do not use wrenches or hammers.*
4. When the process fluid has been completely drained, remove the basket. Clean the basket by using a brush or soaking in an appropriate cleaning solution. **DO NOT USE SOLVENTS ON PLASTIC BASKETS.** Baskets should be cleaned as soon as possible after removal from the strainer; otherwise the contents may harden and become more difficult to remove. *Avoid striking baskets to loosen their contents as this may damage the basket.* To clean the basket strainer body wash the inside of the body with an appropriate cleaning solution. (NOT A SOLVENT)
5. Place a clean basket into the basket strainer body. The basket flange should rest squarely on the basket seat inside the body.
Before replacing the cover, make sure that the “o”-ring for the cover is undamaged, clean, and lubricated. It is good practice to clean the body threads with a soft brush to remove all foreign material. **TIGHTEN THE COVER USING LIGHT HAND PRESSURE ONLY.** The cover holds the basket in place ensuring no material passes the basket. The cover is forced against the top surface of the body when tightening, as the seal is performed with a flat sealing action.
6. Reinstall the drain plug. Tighten the vent plug, if it has been loosened.

- **ADJUSTMENT OF VALVES:**

**EXTREME CAUTION MUST BE TAKEN WHEN WORKING ON THE VALVES
THE PIPING SYSTEM MUST BE DEPRESSURIZED AND COMPLETELY DRAINED. PROPER
CARE MUST BE TAKEN. CONSULT M.S.D.S. (MATERIAL SAFETY DATA SHEETS)
INFORMATION REGARDING YOUR SPECIFIC APPLICATION.**

Rotation of the assembly nut on this design will move the end connector toward the seats. These valves are of the “TRUE UNION” design such that a leaking valve must be totally removed from service to adjust and stop the leaking.

- **REPAIR OF VALVES:**

The valves are a cartridge design. Unscrewing both assembly nuts completely in the counter clockwise direction and disengaging them from the valve bodies will allow an individual valve to be lifted out of the assembly. Slight valve leakage may be stopped by carefully tightening the seal retainer in the clockwise direction. NOTE: Excess seal retainer torque will cause extreme valve stem torque and can cause ball failure.

Follow the adjustment sequence and information above, but rotating the seal retainer completely in the counter-clockwise direction and remove it from valve body. **Take note of the Ball position when the ball is removed from the valve.** The o-rings and seals are now accessible for replacement using a “seal” repair kit. Carefully remove the o-rings from their respective locations taking care not to scratch their sealing surfaces. Use a non-petroleum base lubricant to lubricate the o-rings, and re-assemble the valve. See table below.

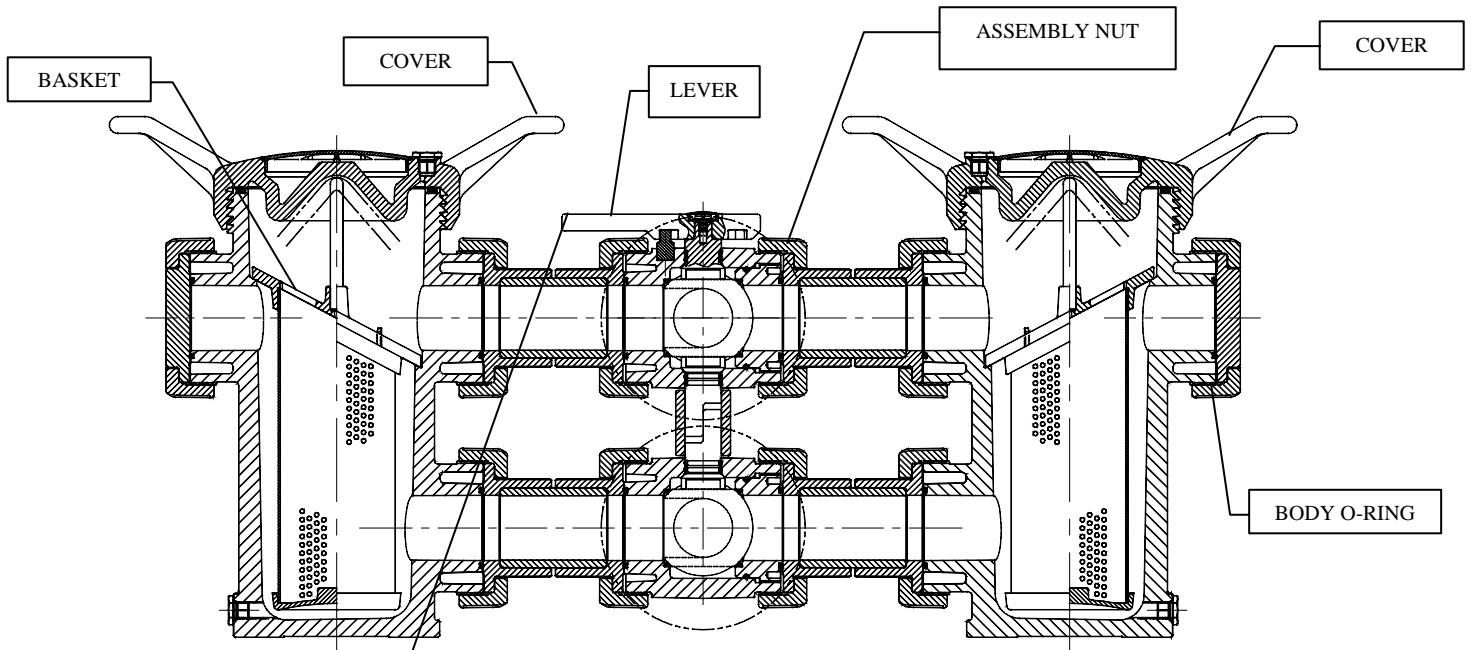

WITH LEVER IN THIS POSITION, THIS BASKET STRAINER IS ACTIVE. SERVICE THE OPPOSITE STRAINER

Operating Temperature vs. Pressure

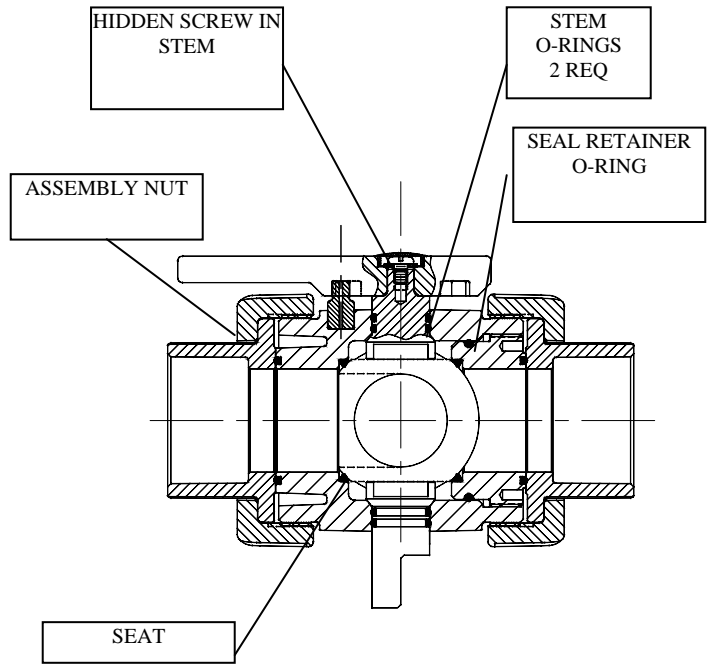
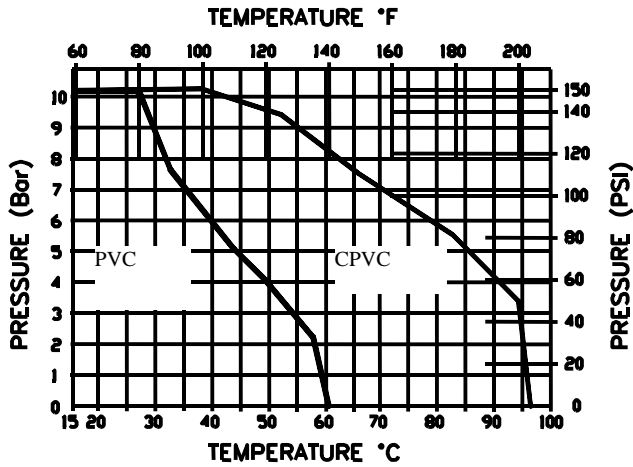

VALVE ILLUSTRATED

Recommended valve stem torque to rotate the ball 360° when valve is reassembled.

VALVE SIZE	TORQUE IN*LB
1/2"	30
3/4"	40
1"	50
1 1/4"	60
1 1/2"	60
2"	80
3"	180
4" & 6"	220