

# PRESSURE FILTER, manifold mounted

## Series MNU 250 - 400 3600 PSI

Sheet No.  
**1428 K**

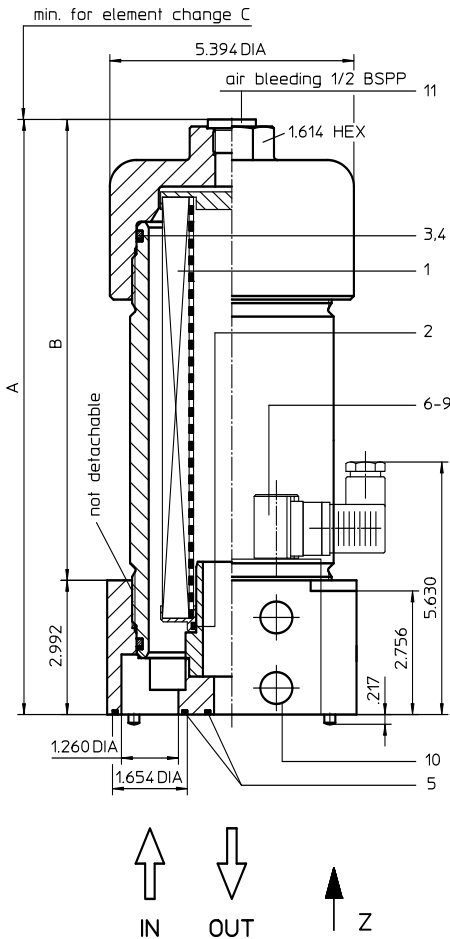

view "Z"

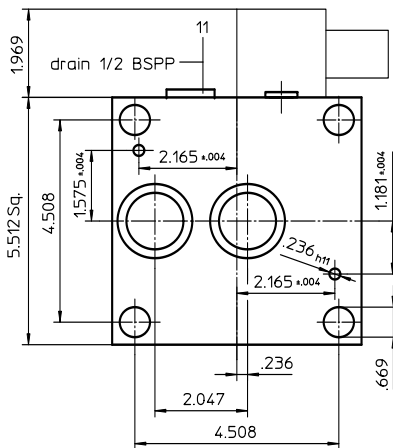

### 1. Type index:

#### 1.1. Complete filter: (ordering example)

**MNU.250.10VG.30.E.P.-.P.6.-.-.AE**

1	2	3	4	5	6	7	8	8	10	11	12
---	---	---	---	---	---	---	---	---	----	----	----

- 1 **series:**  
MNU = medium pressure standard filter for manifold mounted
- 2 **nominal size:** 250, 400
- 3 **filter-material and filter-fineness:**  
80 G = 80  $\mu\text{m}$ , 40 G = 40  $\mu\text{m}$ , 25 G = 25  $\mu\text{m}$  stainless steel wire mesh  
25 VG = 20  $\mu\text{m}_{(c)}$ , 16 VG = 15  $\mu\text{m}_{(c)}$ , 10 VG = 10  $\mu\text{m}_{(c)}$ ,  
6 VG = 7  $\mu\text{m}_{(c)}$ , 3 VG = 5  $\mu\text{m}_{(c)}$  Interpor fleece (glass fibre)
- 4 **resistance of pressure difference for filter element :**  
30 =  $\Delta p$  435 PSI  
HR =  $\Delta p$  2320 PSI (rupture strength  $\Delta p$  3625 PSI)
- 5 **filter element design:**  
E = single-end open
- 6 **sealing material:**  
P = Nitrile (NBR)  
V = Viton (FPM)
- 7 **filter element specification:**  
- = standard  
VA = stainless steel
- 8 **connection:**  
P = manifold mounted
- 9 **connection size:**  
6 = 1 1/4"
- 10 **filter element specification:**  
- = standard
- 11 **internal valve:**  
- = without  
S1 = with by-pass valve  $\Delta p$  51 PSI  
S2 = with by-pass valve  $\Delta p$  102 PSI
- 12 **clogging indicator or clogging sensor :**  
- = without  
AE = visual-electrical, see sheet-no. 1609  
VS1 = electronic, see sheet-no. 1607  
VS2 = electronic, see sheet-no. 1608

#### 1.2. Filter element: (ordering example)

**01NL.250.10VG.30.E.P.-**

1	2	3	4	5	6	7
---	---	---	---	---	---	---

- 1 **series:**  
01NL. = standard filter element according to DIN 24 550, T3
- 2 **nominal size:** 250, 400
- 3 - 7 see type index-complete filter

### 2. Dimensions: inch

type	connection	A	B	C	weight lbs.	volume tank
MNU 250	1 1/4"	13.27	10.28	8.27	44	.42 Gal.
MNU 400	1 1/4"	19.18	16.18	14.17	53	.68 Gal.

### 3. Spare parts:

item	qty.	designation	dimension		article-no.	
			MNU 250	MNU 400		
1	1	filter element	01NL. 250	01NL. 400		
2	1	O-ring	40 x 3		304389 (NBR)	304391 (FPM)
3	1	O-ring	98 x 4		301914 (NBR)	304765 (FPM)
4	1	support ring	107 x 3,5 x 1,5		317663	
5	2	O-ring	36 x 3		304358 (NBR)	313900 (FPM)
6	1	clogging indicator,visual-electrical	AE		see sheet-no. 1609	
7	1	clogging sensor,electrical	VS1		see sheet-no. 1607	
8	1	clogging sensor,electrical	VS2		see sheet-no. 1608	
9	2	O-ring	14 x 2		304342 (NBR)	304722 (FPM)
10	2	screw plug	1/8 BSPP		304791	
11	2	screw plug	1/2 BSPP		304678	

item 10 execution only without clogging indicator and clogging sensor

### 4. Description:

Pressure filters of the series MNU are suitable for a working pressure up to 3600 PSI and equipped with filter elements according to DIN 24550, T3. The pressure peaks are absorbed by a sufficient margin of safety.

The MNU-filters are flange-mounted to the hydraulic system.

The filter element consists of star-shaped, pleated filter material which is supported on the inside by a perforated core tube and is bonded to the end caps with a high-quality adhesive.

The flow direction is from outside to the inside. Filter elements are available down to 4  $\mu\text{m}_{(c)}$ .

Internormen Product Line filter elements are known as elements with a high intrinsic stability and an excellent filtration capability, a high dirt-retaining capacity and a long service life.

Internormen Product Line filter are suitable for all petroleum based fluids, HW-emulsions, most synthetic hydraulic fluids and lubrication oils.

Internormen Product Line filter elements are available up to a pressure difference resistance of  $\Delta p$  2320 PSI and a rupture strength of  $\Delta p$  3625 PSI.

The internal valves are integrated into the centering pivot for the filter element.

After reaching the opening pressure the by-pass valve causes that an unfiltered partial flow passes the filter.

### 5. Technical data:

temperature range:	+14°F to 176°F (for a short time 212°F)
operating medium:	mineral oil, other media on request
max. operating pressure:	3600 PSI
test pressure:	5200 PSI
connection system:	manifold mounted
housing material:	C-steel
sealing material:	Nitrile (NBR) or Viton (FPM), other materials on request
installation position:	vertical

Classified under the Pressure Equipment Directive 97/23/EC for mineral oil (fluid group 2), Article 3, Para. 3.

Classified under ATEX Directive 94/9/EC according to specific application (see questionnaire sheet-no. 34279-4).

### 6. Symbols:

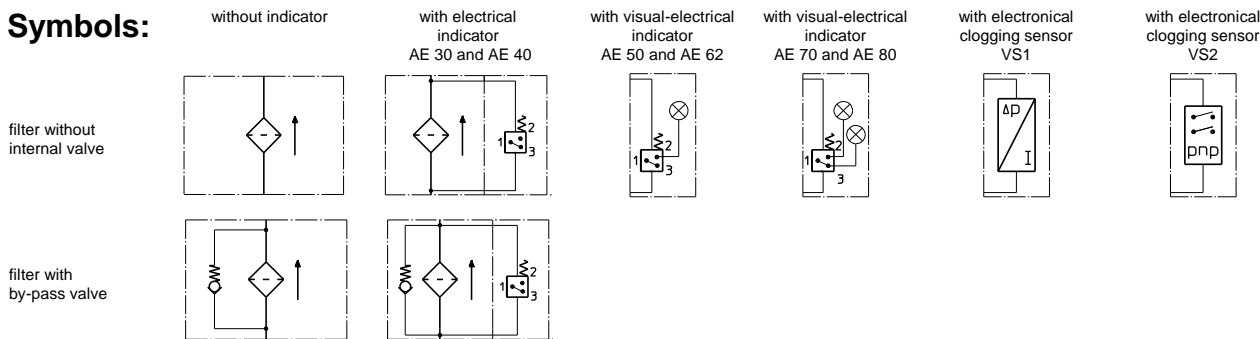

### 7. Pressure drop flow curves:

Precise flow rates see 'Interactive Product Specifier', respectively  $\Delta p$ -curves; depending on filter fineness and viscosity.

### 8. Test methods:

Filter elements are tested according to the following ISO standards:

ISO 2941	Verification of collapse/burst resistance
ISO 2942	Verification of fabrication integrity
ISO 2943	Verification of material compatibility with fluids
ISO 3723	Method for end load test
ISO 3724	Verification of flow fatigue characteristics
ISO 3968	Evaluation of pressure drop versus flow characteristics
ISO 16889	Multi-pass method for evaluating filtration performance

# PRESSURE FILTER, manifold mounted

## Series MNU 255 3625 PSI

Sheet No.  
**1418 C**

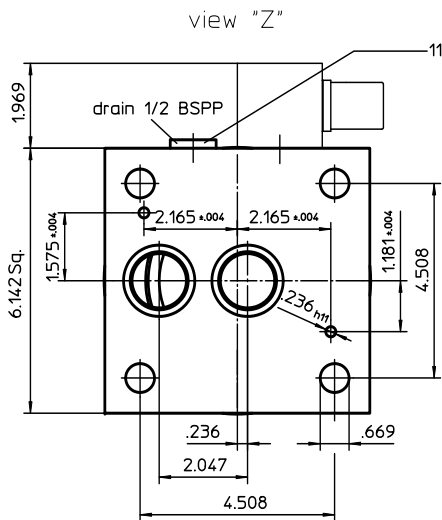
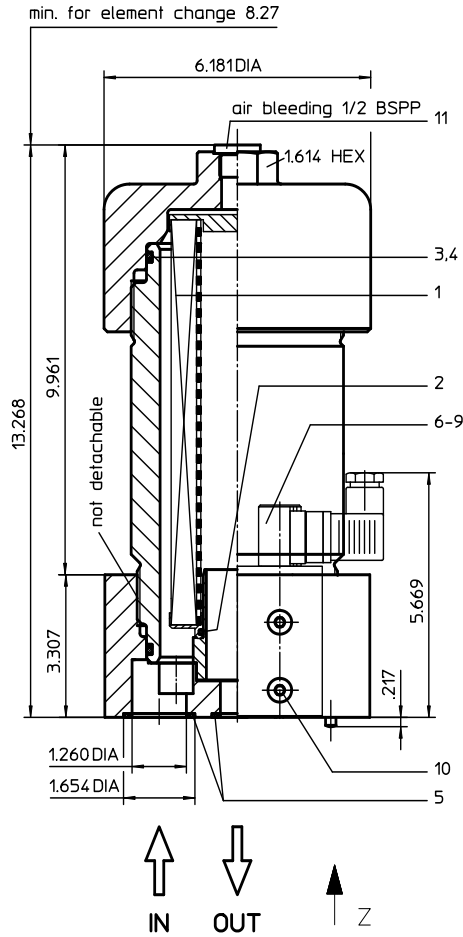

### 1. Type index:

#### 1.1. Complete filter: (ordering example)

**MNU.255.10VG.30.E.P.-.P.6.-.-.AE**

1	2	3	4	5	6	7	8	9	10	11	12
---	---	---	---	---	---	---	---	---	----	----	----

##### 1 series:

MNU = medium pressure standard filter for manifold mounted

##### 2 nominal size: 255

##### 3 filter-fineness and filter-material:

80 G = 80  $\mu\text{m}$ , 40 G = 40  $\mu\text{m}$ , 25 G = 25  $\mu\text{m}$  stainless steel wire mesh  
 25 VG = 20  $\mu\text{m}_{(c)}$ , 16 VG = 15  $\mu\text{m}_{(c)}$ , 10 VG = 10  $\mu\text{m}_{(c)}$ ,  
 6 VG = 7  $\mu\text{m}_{(c)}$ , 3 VG = 5  $\mu\text{m}_{(c)}$  Interpor fleece (glass fiber)

##### 4 resistance of pressure difference for filter element:

30 =  $\Delta p$  435 PSI  
 HR =  $\Delta p$  2320 PSI (rupture strength  $\Delta p$  3625 PSI)

##### 5 filter element design:

E = single-end open

##### 6 sealing material:

P = Nitrile (NBR)  
 V = Viton (FPM)

##### 7 filter element specification:

- = standard  
 VA = stainless steel

##### 8 connection:

P = manifold mounted

##### 9 connection size:

6 = 1 1/4"

##### 10 filter housing specification:

- = standard

##### 11 internal valve:

- = without  
 S1 = with by-pass valve  $\Delta p$  51 PSI  
 S2 = with by-pass valve  $\Delta p$  102 PSI

##### 12 clogging indicator or clogging sensor:

- = without  
 AE = visual-electrical, see sheet-no. 1609  
 VS1 = electrical, see sheet-no. 1607  
 VS2 = electrical, see sheet-no. 1608

#### 1.2. Filter element: (ordering example)

**01NL.250.10VG.30.E.P.-**

1	2	3	4	5	6	7
---	---	---	---	---	---	---

##### 1 series:

01NL. = standard filter element according to DIN 24 550, T3

##### 2 nominal size: 250

3 - 7 | see type index-complete filter

weight: approx. 62 lbs.

Changes of measures and design are subject to alteration!

## 2. Spare parts:

item	qty.	designation	dimension	article-no.	
1	1	filter element	01NL. 250		
2	1	O-ring	40 x 3	304389 (NBR)	304391 (FPM)
3	1	O-ring	98 x 4	301914 (NBR)	304765 (FPM)
4	1	support ring	107 x 3,5 x 1,5	317663	
5	2	O-ring	36 x 3	304358 (NBR)	313900 (FPM)
6	1	clogging indicator,visual-electrical	AE	see sheet-no. 1609	
7	1	clogging sensor,electrical	VS1	see sheet-no. 1607	
8	1	clogging sensor,electrical	VS2	see sheet-no. 1608	
9	2	O-ring	14 x 2	304342 (NBR)	304722 (FPM)
10	2	screw plug	1/8" BSPP	304791	
11	2	screw plug	1/2" BSPP	304678	

item 10 execution only without clogging indicator and clogging sensor

## 3. Description:

Pressure filters of the series MNU 255 are suitable for a working pressure up to 3625 PSI and equipped with filter elements according to DIN 24550, T3. The pressure peaks are absorbed by a sufficient margin of safety. The MNU-filters are flange-mounted to the hydraulic system.

The filter element consists of star-shaped, pleated filter material which is supported on the inside by a perforated core tube and is bonded to the end caps with a high-quality adhesive.

The flow direction is from outside to the inside. Filter elements are available down to 4  $\mu\text{m}_{(c)}$ .

Internormen Product Line filter elements are known as elements with a high intrinsic stability and an excellent filtration capability, a high dirt-retaining capacity and a long service life.

Internormen Product Line filter are suitable for all petroleum based fluids, HW-emulsions, most synthetic hydraulic fluids and lubrication oils.

Internormen Product Line filter elements are available up to a pressure difference resistance of  $\Delta p$  2320 PSI and a rupture strength of  $\Delta p$  3625 PSI.

The internal valves are integrated into the centering pivot for the filter element.

After reaching the opening pressure the by-pass valve causes that an unfiltered partial flow passes the filter.

## 4. Technical data:

temperature range:	+14°F to 176°F (for a short time 212°F)
operating medium:	mineral oil, other media on request
max. operating pressure:	3625 PSI
test pressure:	5190 PSI
connection system:	manifold mounted
housing material:	C-steel/tempering steel
sealing material:	Nitrile (NBR) or Viton (FPM), other materials on request
installation position:	vertical
volume tank:	.42 Gal

Classified under the Pressure Equipment Directive 97/23/EC for mineral oil (fluid group 2), Article 3, Para. 3.

Classified under ATEX Directive 94/9/EC according to specific application (see questionnaire sheet-no. 34279-4).

## 5. Symbols:

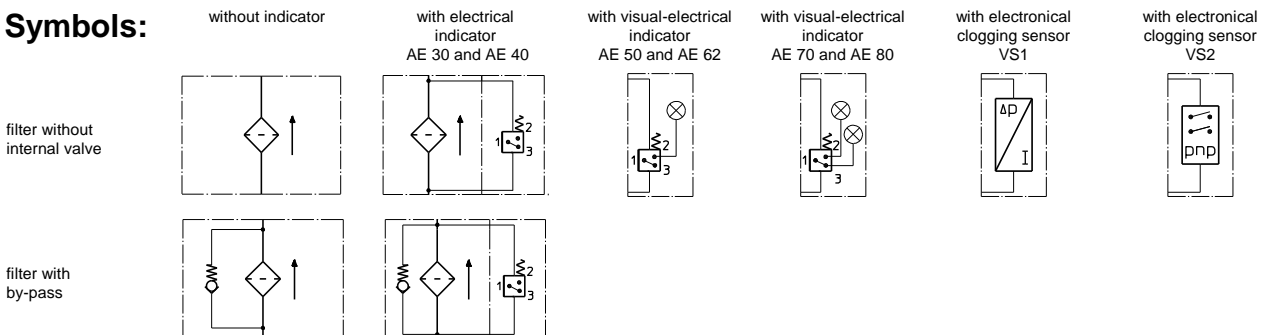

## 6. Pressure drop flow curves:

Precise flow rates see 'Interactive Product Specifier', respectively  $\Delta p$ -curves; depending on filter fineness and viscosity.

## 7. Test methods:

Filter elements are tested according to the following ISO standards:

ISO 2941	Verification of collapse/burst resistance
ISO 2942	Verification of fabrication integrity
ISO 2943	Verification of material compatibility with fluids
ISO 3723	Method for end load test
ISO 3724	Verification of flow fatigue characteristics
ISO 3968	Evaluation of pressure drop versus flow characteristics
ISO 16889	Multi-pass method for evaluating filtration performance