

Series MDV 40-63 2900 PSI

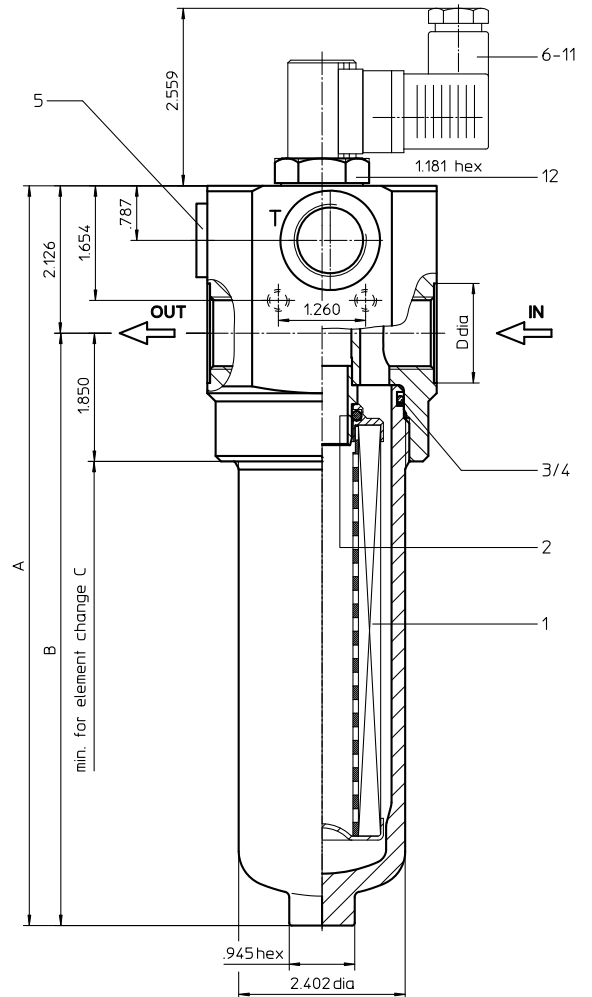
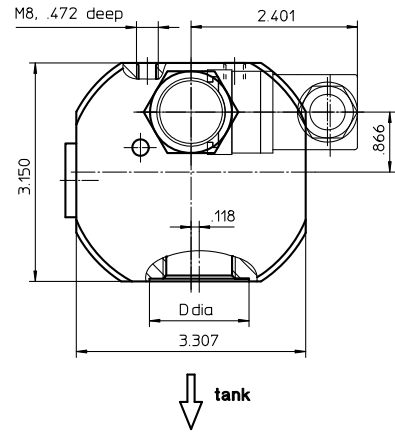

Dimensions:

type	MDV 40	MDV 63
connection	- 8 SAE	-12 SAE
A	8.30	10.67
B	6.18	8.54
C	10.43	12.80
weight approx.	5.94 lbs.	7.04 lbs.
volume tank	0.06 Gal.	0.09 Gal.

Dimensions: inches

Designs and performance values are subject to change.

Pressure Filter

Series MDV 40-63

2900 PSI

Description:

Pressure filter series MDV have a working pressure up to 2900 PSI. The pressure peaks are absorbed by a sufficient margin of safety. The MDV-filter is in-line mounted.

The filter element meets DIN 24550T3 and consists of star-shaped, pleated filter material which is supported on the inside by a perforated core tube and is bonded to the end caps with a high-quality adhesive. The flow direction is from outside to the inside. Filter elements are available down to 5 $\mu\text{m}_{(c)}$. Finer filtration is available upon request.

Eaton filter elements are known for high intrinsic stability and an excellent filtration capability, a high dirt-retaining capacity and a long service life.

Eaton filter elements are suitable for all petroleum based fluids, HW-emulsions, most synthetic hydraulic fluids and lubrication oils.

Eaton filter elements are available up to a pressure resistance of Δp 2320 PSI and a rupture strength of Δp 3625 PSI.

The internal valve is integrated into the filter head. The differential pressure valve diverts the contaminated fluid to the tank when the element is clogged. During cold start, the differential pressure valve will divert the fluid to the tank until the system warms up.

1. Type index:

1.1. Complete filter: (ordering example)

MDV. 40. 10VG. HR. E. P. - UG. 3. - D2.AE

1	2	3	4	5	6	7	8	9	10	11	12
---	---	---	---	---	---	---	---	---	----	----	----

- | | |
|----|--|
| 1 | series:
MDV = medium pressure filter with differential pressure-valve |
| 2 | nominal size: 40, 63 |
| 3 | filter-material and filter-fineness:
80G, 40G, 25G stainless steel wire mesh
25VG, 16VG, 10VG, 6VG, 3VG microglass |
| 4 | filter element collapse rating:
30 = Δp 435 PSI
HR = Δp 2320 PSI (rupture strength Δp 3625 PSI) |
| 5 | filter element design:
E = single-end open |
| 6 | sealing material:
P = Nitrile (NBR)
V = Viton (FPM) |
| 7 | filter element specification:
- = standard
VA = stainless steel |
| 8 | process connection:
UG = thread connection |
| 9 | process connection size:
3 = -8 SAE
4 = -12 SAE |
| 10 | filter housing specification:
- = standard |
| 11 | internal valve:
D1 = differential pressure-valve Δp 51 PSI
D2 = differential pressure-valve Δp 102 PSI |
| 12 | clogging indicator or clogging sensor:
- = without
AOR = visual, see sheet-no. 1606
AOC = visual, see sheet-no. 1606
AE = visual-electric, see sheet-no. 1615
VS5 = electronic, see sheet-no. 1619 |

To add an indicator to your filter, use the corresponding indicator data sheet to find the indicator details and add them to the filter assembly model code.

1.2. Filter element: (ordering example)

01NL. 40. 10VG. HR. E. P. -

1	2	3	4	5	6	7
---	---	---	---	---	---	---

- | | |
|---|--|
| 1 | series:
01NL. = standard filter element according to DIN 24550, T3 |
| 2 | nominal size: 40, 63 |
| 3 | - 7 see type index-complete filter |

Technical data:

design temperature:	14 °F to +212 °F
operating temperature:	14 °F to +176 °F
operating medium	mineral oil, other media on request
max. operating pressure:	2900 PSI
test pressure:	4147 PSI
process connection:	thread connection
housing material:	aluminum forging alloy, C-steel
sealing material:	Nitrile (NBR) or Viton (FPM), other materials on request
installation position:	vertical
air bleeding and mini-measuring connections dirt side:	BSPP ¼
measuring connections clean side:	BSPP ½

Classified under the Pressure Equipment Directive 2014/68/EC for mineral oil (fluid group 2), Article 4, Para. 3.
 Classified under ATEX Directive 2014/34/EC according to specific application (see questionnaire sheet-no. 34279-4).

Pressure drop flow curves:

Filter calculation/sizing

The pressure drop of the assembly at a given flow rate Q is the sum of the housing Δp and the element Δp and is calculated as follows:

$$\Delta p_{assembly} = \Delta p_{housing} + \Delta p_{element}$$

$$\Delta p_{housing} = (\text{see } \Delta p = f(Q) \text{ - characteristics})$$

$$\Delta p_{element} (PSI) = Q (GPM) \times \frac{MSK}{1000} \left(\frac{PSI}{GPM} \right) \times v(SUS) \times \frac{\rho}{0.876} \left(\frac{kg}{dm^3} \right)$$

For ease of calculation our Filter Selection tool is available online at www.eatonpowersource.com/calculators/filtration/

Material gradient coefficients (MSK) for filter elements

The material gradient coefficients in PSI/GPM apply to mineral oil (HLP) with a density of 0.876 kg/dm³ and a kinematic viscosity of 139 SUS (30 mm²/s). The pressure drop changes proportionally to the change in kinematic viscosity and density.

MDV	VG				
	3VG	6VG	10VG	16VG	25VG
40	6.991	4.853	3.107	2.705	1.848
63	4.214	2.926	1.873	1.631	1.114

$\Delta p = f(Q)$ – characteristics according to ISO 3968

The pressure drop characteristics apply to mineral oil (HLP) with a density of 0.876 kg/dm³. The pressure drop changes proportionally to the density.

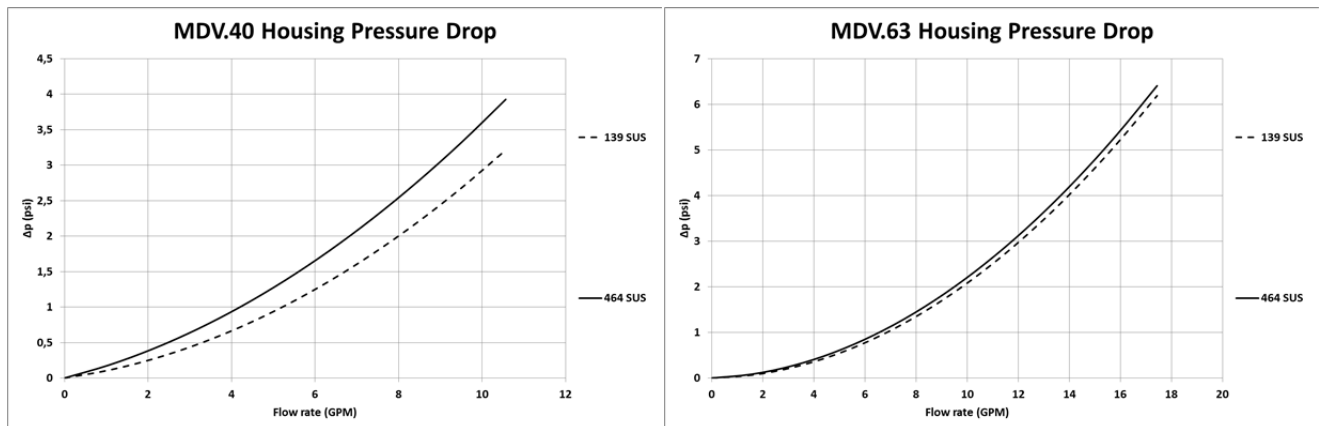

Symbols:

without indicator

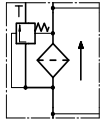

with electric indicator
AE 30 and AE 40

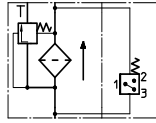

with visual-electric indicator
AE 50 and AE 62

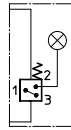

with visual-electric indicator
AE 70 and AE 80

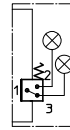

with visual indicator
AOR/AOC

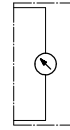

with electronic clogging sensor
VS5

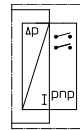

Spare parts:

item	qty.	designation	dimension		article-no.	
			MDV 40	MDV 63		
1	1	filter element	01NL.40...	01NL.63...		
2	1	O-ring	22 x 3,5		304341 (NBR)	304392 (FPM)
3	1	O-ring	54 x 3		304657 (NBR)	304720 (FPM)
4	1	support ring	60 x 2,6 x 1			311779
5	1	screw plug	1/2 BSPP			304678
6	1	clogging indicator visual	AOR or AOC			see sheet-no. 1606
7	1	clogging indicator visual-electric	AE			see sheet-no. 1615
8	1	clogging sensor electronic	VS5			see sheet-no. 1619
9	1	O-ring	15 x 1,5		315357 (NBR)	315427 (FPM)
10	1	O-ring	22 x 2		304708 (NBR)	304721 (FPM)
11	1	O-ring	14 x 2		304342 (NBR)	304722 (FPM)
12	1	screw plug	20913-4			309817

item 12 execution only without clogging indicator or clogging sensor

Test methods:

Filter elements are tested according to the following ISO standards:

ISO 2941	Verification of collapse/burst resistance
ISO 2942	Verification of fabrication integrity
ISO 2943	Verification of material compatibility with fluids
ISO 3723	Method for end load test
ISO 3724	Verification of flow fatigue characteristics
ISO 3968	Evaluation of pressure drop versus flow characteristics
ISO 16889	Multi-pass method for evaluating filtration performance