

Series DUV 1050-2050 464 PSI

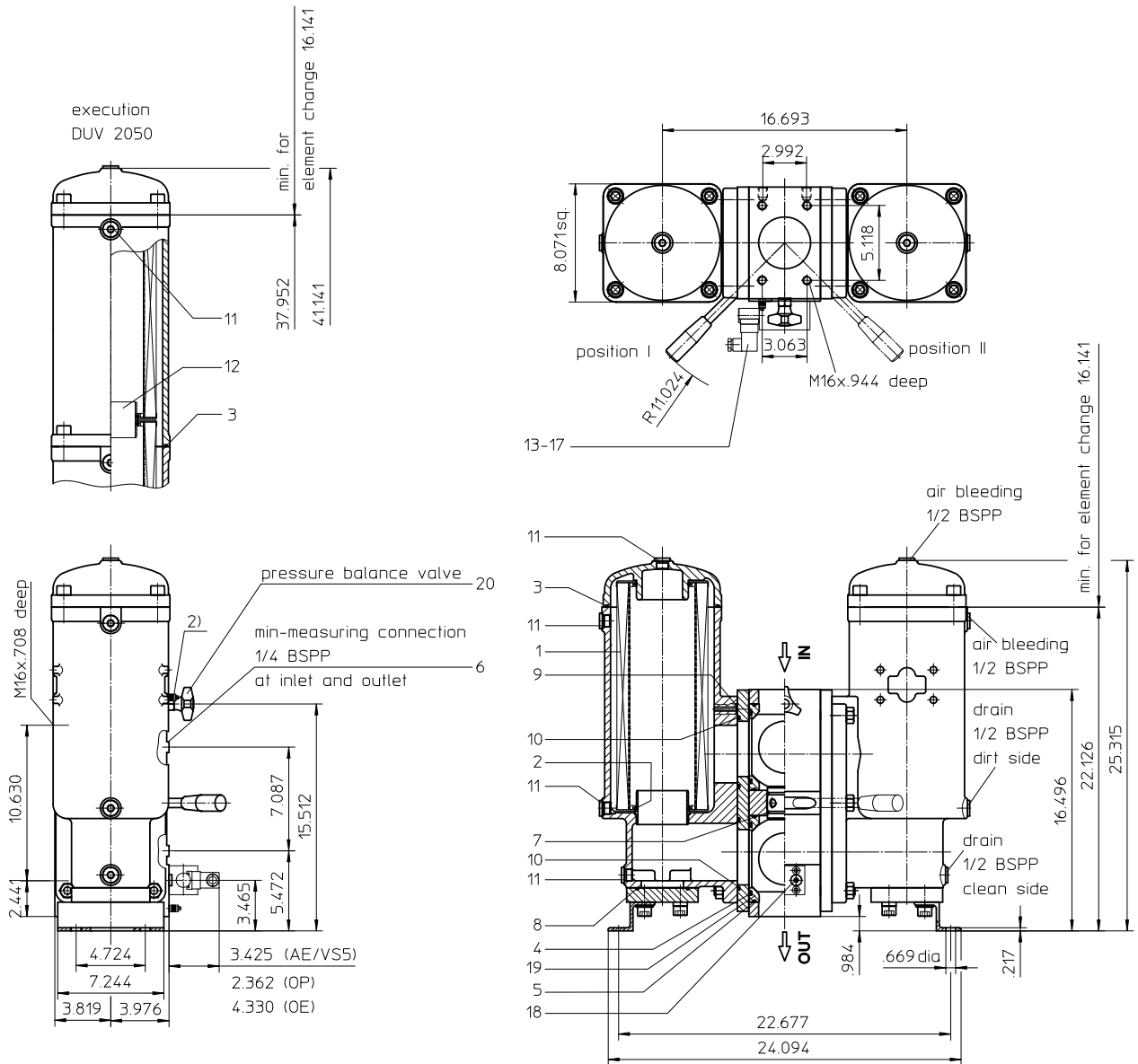

2) Connect the stand grounding tab to a suitable earth ground point.

Position I: Left filter-side in operation
Position II: Right filter-side in operation

Dimensions:

type	connection	SAE-connection size	weight
DUV 1050	SAE 3" ¹⁾	SAE 4" 3000 PSI	330 lbs.
DUV 1050	SAE 4"	SAE 4" 3000 PSI	330 lbs.
DUV 2050	SAE 3" ¹⁾	SAE 4" 3000 PSI	440 lbs.
DUV 2050	SAE 4"	SAE 4" 3000 PSI	440 lbs.

¹⁾ with reducing flange BFS.B.E.88,9x3,2.St.P.3000 / Instead of P (Nitrile) also V (Viton) can be chosen.

Dimensions: inches

Designs and performance values are subject to change.

Pressure Filter

Series DUV 1050-2050

464 PSI

Description:

Duplex filter series DUV 1050-2050 have a working pressure up to 464 PSI. Pressure peaks can be absorbed with a sufficient safety margin.

A change over ball valve between the two filter housings makes it possible to switch from the dirty filter-side to the clean filter-side without interrupting operation.

The filter element consists of star-shaped, pleated filter material, which is supported on the inside by a perforated core tube and is bonded to the end caps with a high-quality adhesive. The flow direction is from outside to inside.

For cleaning the mesh element or changing the microglass element, remove the cover and take out the element. The mesh elements are not guaranteed to maintain 100% performance after cleaning.

For filtration finer than 40 µm, use the disposable elements made of microglass. Filter elements as fine as 5 µm(c) are available; finer filter elements are available upon request.

Eaton-filter elements are known for a high intrinsic stability and an excellent filtration capability, a high dirt-retaining capacity and a long service life.

Eaton filter elements are suitable for all petroleum based fluids, HW-emulsions, most synthetic hydraulic fluids and lubrication oils.

The internal valve is integrated in the filter cover. After reaching the opening pressure the by-pass valve causes that an unfiltered partial flow passes the filter.

Ship classifications available upon request.

Type index:

Complete filter: (ordering example)

DUV. 1050. 10VG. 10. B. P. -. FS. B. -. -. AE
1 2 3 4 5 6 7 8 9 10 11 12

- 1 series:**
DUV = pressure filter, change over with vertical connecting pipe
- 2 nominal size:** 1050, 2050
- 3 filter-material and filter-fineness:**
80G, 40G, 25G, 10G stainless steel wire mesh
25VG, 16VG, 10VG, 6VG, 3VG microglass
25API, 10API microglass according to API
10P paper
- 4 filter element collapse rating:**
10 = Δp 145 PSI
- 5 filter element design:**
B = both sides open
- 6 sealing material:**
P = Nitrile (NBR)
V = Viton (FPM)
- 7 filter element specification:** (see catalog)
- = standard
VA = stainless steel
IS06 = for HFC application, see sheet-no. 31601
IS07 = for oil/amonia mixtures (NH₃), see sheet-no. 31602
- 8 process connection:**
FS = SAE-flange 3000 PSI
- 9 process connection size:**
B = 4"
- 10 filter housing specification:** (see catalog)
- = standard
IS06 = for HFC application, see sheet-no. 31605
IS12 = for stainless steel ball valve, see sheet-no. 41028
IS20 = ASME VIII Div.1 with ASME equivalent material, see sheet-no. 55217 (operating pressure max. 232 PSI)
- 11 internal valve:**
- = without
S = with by-pass valve Δp 29 PSI
S1 = with by-pass valve Δp 51 PSI
- 12 clogging indicator or clogging sensor:**
- = without
AE = visual-electric, see sheet-no.1609
OP = visual, see sheet-no.1628
OE = visual-electric, see sheet-no.1628
VS5 = electronic, see sheet-no.1641

To add an indicator to your filter, use the corresponding indicator data sheet to find the indicator details and add them to the filter assembly model code.

Filter element: (ordering example)

01NR. 1000. 10VG. 10. B. P. -
1 2 3 4 5 6 7

- 1 series:**
01NR. = standard-return-line filter element according to DIN 24550, T4
- 2 nominal size:** 1000
- 3 - 7** see type index complete filter

Accessories:

- gauge port and bleeder connection, see sheet-no. 1650
- drain- and bleeder connection, see sheet-no. 1651
- SAE-counter flange, see sheet-no. 1652
- shut-off valve, see sheet-no. 1655

Technical data:

design temperature:	14 °F to +212 °F
operating temperature:	14 °F to +176 °F
operating medium	mineral oil, other media on request
max. operating pressure:	464 PSI
max. operating pressure at IS20:	232 PSI
test pressure:	900 PSI
test pressure at IS20:	464 PSI
process connection:	SAE-flange 3000 PSI
housing material:	EN-GJS-400-18-LT
switching housing material:	S355J2 + N
sealing material:	Nitrile (NBR) or Viton (FPM), other materials on request
installation position:	vertical
measure connections:	BSPP ¼
drain- and bleeder connections:	BSPP ½
volume tank DUV 1050:	2x 3.6 Gal.
DUV 2050:	2x 6.3 Gal.

Classified under the Pressure Equipment Directive 2014/68/EC for mineral oil (fluid group 2), Article 4, Para. 3.
 Classified under ATEX Directive 2014/34/EC according to specific application (see questionnaire sheet-no. 34279-4).

Pressure drop flow curves:

Filter calculation/sizing

The pressure drop of the assembly at a given flow rate Q is the sum of the housing Δp and the element Δp and is calculated as follows:

$$\Delta p_{assembly} = \Delta p_{housing} + \Delta p_{element}$$

$$\Delta p_{housing} = (\text{see } \Delta p = f(Q) - \text{characteristics})$$

$$\Delta p_{element} (PSI) = Q (GPM) \times \frac{MSK}{1000} \left(\frac{PSI}{GPM} \right) \times \nu (SUS) \times \frac{\rho}{0,876} \left(\frac{kg}{dm^3} \right)$$

For ease of calculation our Filter Selection tool is available online at www.eatonpowersource.com/calculators/filtration/

Material gradient coefficients (MSK) for filter elements

The material gradient coefficients in psi/gpm apply to mineral oil (HLP) with a density of 0,876 kg/dm³ and a kinematic viscosity of 139 SUS (30 mm²/s). The pressure drop changes proportionally to the change in kinematic viscosity and density.

DUV	VG					G			P	API	
	3VG	6VG	10VG	16VG	25VG	25G	40G	80G	10P	10API	25API
1050	0.237	0.165	0.105	0.092	0.063	0.0061	0.0057	0.0039	0.051	0.053	0.024
2050	0.118	0.082	0.053	0.046	0.031	0.0030	0.0028	0.0019	0.026	0.027	0.012

$\Delta p = f(Q)$ – characteristics according to ISO 3968

The pressure drop characteristics apply to mineral oil (HLP) with a density of 0,876 kg/dm³. The pressure drop changes proportionally to the density.

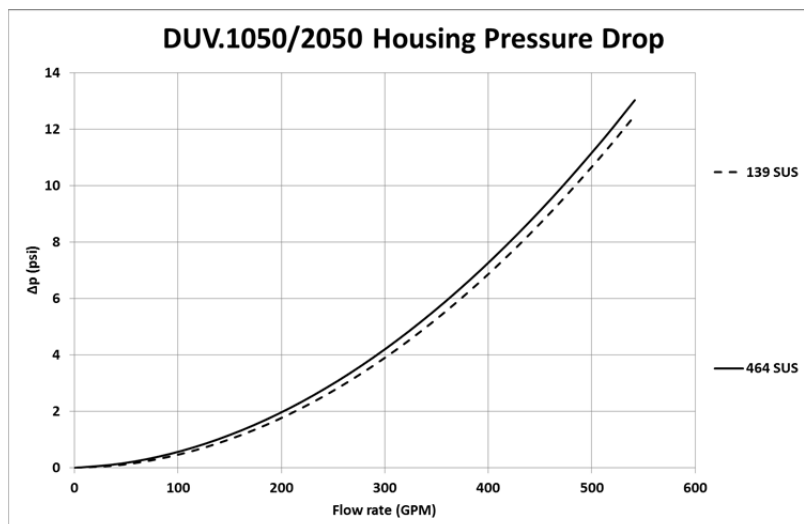

Symbols:

without indicator

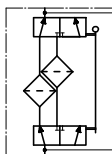

with by-pass valve

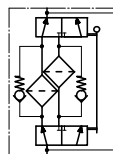

with electric indicator
AE 30 and AE 40

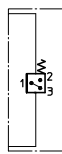

with visual-electric indicator
AE 50 and AE 62

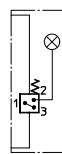

with visual-electric indicator
AE 70 and AE 80

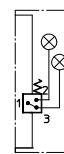

with visual indicator
OP/AOR/AOC

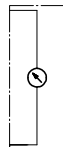

with visual-electrical indicator
OE

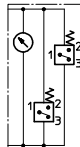

with electronic clogging sensor
VS5

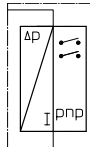

Spare parts:

item	designation	qty.	dimension and article-no.				qty.	dimension and article-no.			
			DUV 1050					DUV 2050			
1	filter element	2	01NR.1000...				4	01NR.1000...			
2	O-ring	4	90 x 4	306941 (NBR)	307031 (FPM)	8	90 x 4	306941 (NBR)	307031 (FPM)		
3	O-ring	2	185 x 4	305593 (NBR)	306309 (FPM)	4	185 x 4	305593 (NBR)	306309 (FPM)		
4	O-ring	4	114 x 6	314419 (NBR)	316531 (FPM)	4	114 x 6	314419 (NBR)	316531 (FPM)		
5	O-ring	4	140 x 4	305145 (NBR)	305201 (FPM)	4	140 x 4	305145 (NBR)	305201 (FPM)		
6	screw plug	2	1/4 BSPP	305003		2	1/4 BSPP	305003			
7	O-ring	2	54 x 3	304657 (NBR)	304720 (FPM)	2	54 x 3	304657 (NBR)	304720 (FPM)		
8	O-ring	2	85,32 x 3,53	305590 (NBR)	306308 (FPM)	2	85,32 x 3,53	305590 (NBR)	306308 (FPM)		
9	O-ring	8	8 x 2	310004 (NBR)	316530 (FPM)	8	8 x 2	310004 (NBR)	316530 (FPM)		
10	O-ring	4	115 x 5	306640 (NBR)	310287 (FPM)	4	115 x 5	306640 (NBR)	310287 (FPM)		
11	screw plug	8	1/2 BSPP	304678		10	1/2 BSPP	304678			
12	slip coupling	-	-	-		2	3,543 dia	313233			
13	clogging indicator visual	1	OP			see sheet-no. 1628					
14	clogging indicator visual-electric	1	OE			see sheet-no. 1628					
15	clogging indicator visual-electric	1	AE			see sheet-no. 1609					
16	clogging sensor electronic	1	VS5			see sheet-no. 1641					
17	O-ring	2	14 x 2	304342 (NBR)				304722 (FPM)			
18	screw plug	2	1/4 BSPP			305003					
19	gasket	4	DN 90			312275					
20	pressure balance valve	1	3/8"			305000					

item 18 execution only without clogging indicator or clogging sensor

Test methods:

Filter elements are tested according to the following ISO standards:

ISO 2941	Verification of collapse/burst resistance
ISO 2942	Verification of fabrication integrity
ISO 2943	Verification of material compatibility with fluids
ISO 3723	Method for end load test
ISO 3724	Verification of flow fatigue characteristics
ISO 3968	Evaluation of pressure drop versus flow characteristics
ISO 16889	Multi-pass method for evaluating filtration performance

Series DUV 2005-4005

493 PSI

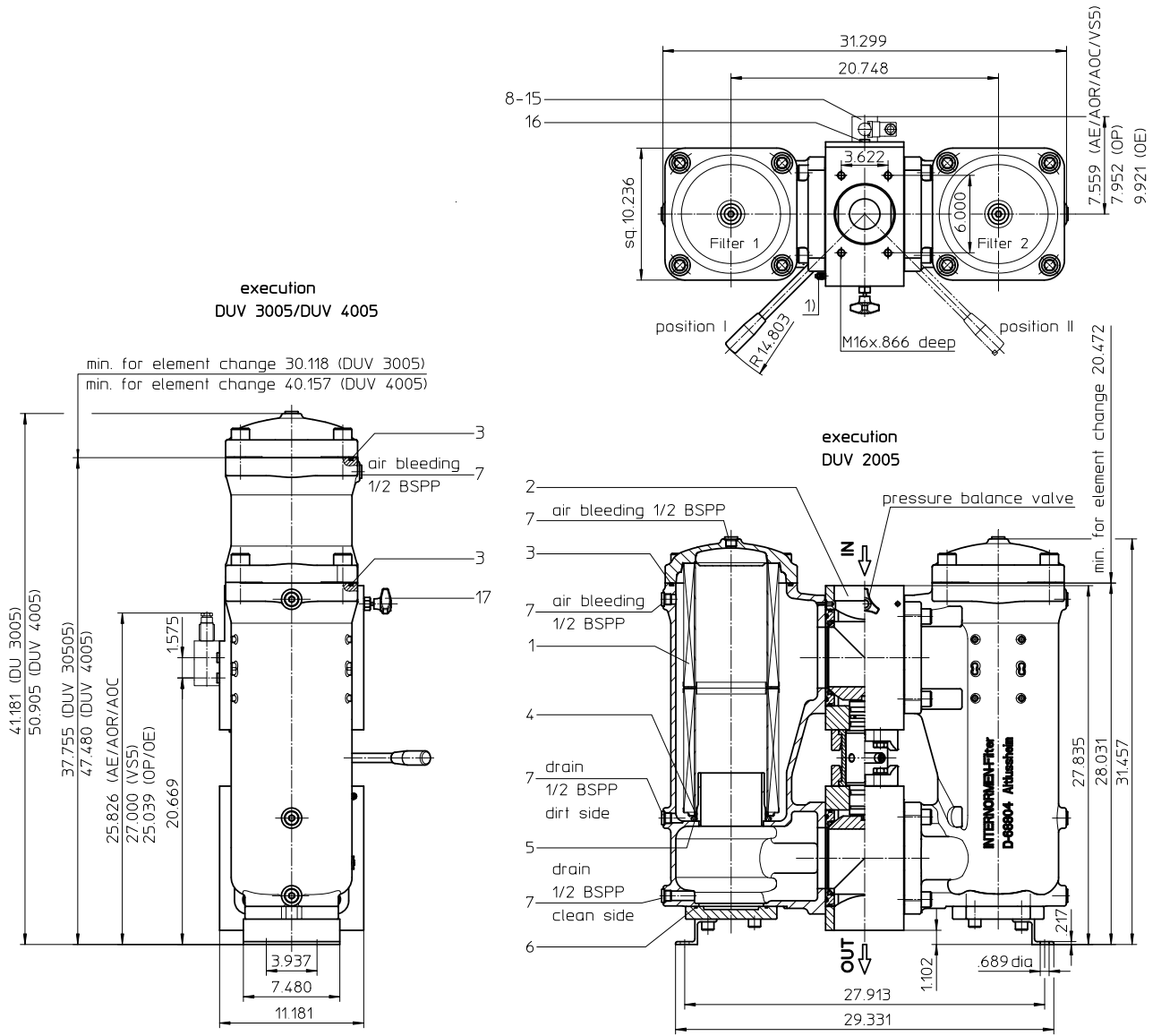

1) Connect the stand grounding tab to a suitable earth ground point.

Position I: Filter 1 in operation
Position II: Filter 2 filter-side in operation

Weight DUV 2005: approx. 750 lbs.
Weight DUV 3005: approx. 886 lbs.
Weight DUV 4005: approx. 961 lbs.

Dimensions: inches

Designs and performance values are subject to change.

Pressure Filter

Series DUV 2005-4005

493 PSI

Description:

Duplex filter series DUV 1050-2050 have a working pressure up to 493 PSI. Pressure peaks can be absorbed with a sufficient safety margin.

A change over ball valve between the two filter housings makes it possible to switch from the dirty filter-side to the clean filter-side without interrupting operation.

The filter element consists of star-shaped, pleated filter material, which is supported on the inside by a perforated core tube and is bonded to the end caps with a high-quality adhesive. The flow direction is from outside to inside.

For cleaning the mesh element or changing the microglass element, remove the cover and take out the element. The mesh elements are not guaranteed to maintain 100% performance after cleaning.

For filtration finer than 40 µm, use the disposable elements made of microglass. Filter elements as fine as 5 µm(c) are available; finer filter elements are available upon request.

Eaton-filter elements are known for a high intrinsic stability and an excellent filtration capability, a high dirt-retaining capacity and a long service life.

Eaton filter elements are suitable for all petroleum based fluids, HW-emulsions, most synthetic hydraulic fluids and lubrication oils.

Ship classifications available upon request.

Type index:

Complete filter: (ordering example)

DUV. 2005. 10VG. 10. E. P. -. FS. C. -. AE

1	2	3	4	5	6	7	8	9	10	11
---	---	---	---	---	---	---	---	---	----	----

1 | series:

DUV = pressure filter, change over with vertical connecting pipe

2 | nominal size: 2005, 3005, 4005

3 | filter-material and filter-fineness:

80G, 40G, 25G, 10G stainless steel wire mesh
 25VG, 16VG, 10VG, 6VG, 3VG microglass
 25API, 10API microglass according to API
 10P paper

4 | filter element collapse rating:

10 = Δp 145 PSI

5 | filter element design:

E = single end open
 S = with by-pass valve Δp 29 PSI

6 | sealing material:

P = Nitrile (NBR)
 V = Viton (FPM)

7 | filter element specification: (see catalog)

- = standard
 VA = stainless steel
 IS06 = for HFC application, see sheet-no. 31601

8 | process connection:

FS = SAE-flange 3000 PSI

9 | process connection size:

C = 5"

10 | filter housing specification: (see catalog)

- = standard
 IS06 = for HFC application, see sheet-no. 31605
 IS12 = for stainless steel ball valve, see sheet-no. 41028
 IS20 = ASME VIII Div.1 with ASME equivalent material,
 see sheet-no. 55217 (operating pressure max. 232 PSI)

11 | clogging indicator or clogging sensor:

- = without
 AOR = visual, see sheet-no.1606
 AOC = visual, see sheet-no.1606
 AE = visual-electric, see sheet-no.1609
 OP = visual, see sheet-no.1628
 OE = visual-electric, see sheet-no.1628
 VS5 = electronic, see sheet-no.1641

To add an indicator to your filter, use the corresponding indicator data sheet to find the indicator details and add them to the filter assembly model code.

Filter element: (ordering example)

01E. 2001. 10VG. 10. E. P. -

1	2	3	4	5	6	7
---	---	---	---	---	---	---

1 | series:

01E. = filter element according to company standard

2 | nominal size: 2001, 3001, 4001

3 | - 7 | see type index complete filter

Accessories:

- gauge port and bleeder connection, see sheet-no. 1650
- drain- and bleeder connection, see sheet-no. 1651
- SAE-counter flange, see sheet-no. 1652
- shut-off valve, see sheet-no. 1655

Technical data:

design temperature:	14 °F to +212 °F
operating temperature:	14 °F to +176 °F
operating medium	mineral oil, other media on request
max. operating pressure:	493 PSI
max. operating pressure at IS20:	232 PSI
test pressure:	986 PSI
test pressure at IS20:	464 PSI
process connection:	SAE-flange 3000 PSI
housing material:	EN-GJS-400-18-LT
switching housing material:	S355J2+N
sealing material:	Nitrile (NBR) or Viton (FPM), other materials on request
installation position:	vertical
measure connections:	BSPP ¼
drain- and bleeder connections:	BSPP ½
volume tank DUV 2005:	2x 8 Gal.
DUV 3005:	2x 10 Gal.
DUV 4005	2x 12 Gal.

Classified under the Pressure Equipment Directive 2014/68/EC for mineral oil (fluid group 2), Article 4, Para. 3.
 Classified under ATEX Directive 2014/34/EC according to specific application (see questionnaire sheet-no. 34279-4).

Pressure drop flow curves:

Filter calculation/sizing

The pressure drop of the assembly at a given flow rate Q is the sum of the housing Δp and the element Δp and is calculated as follows:

$$\Delta p_{assembly} = \Delta p_{housing} + \Delta p_{element}$$

$$\Delta p_{housing} = (\text{see } \Delta p = f(Q) - \text{characteristics})$$

$$\Delta p_{element} (PSI) = Q (GPM) \times \frac{MSK}{1000} \left(\frac{PSI}{GPM} \right) \times \nu (SUS) \times \frac{\rho}{0,876} \left(\frac{kg}{dm^3} \right)$$

For ease of calculation our Filter Selection tool is available online at www.eatonpowersource.com/calculators/filtration/

Material gradient coefficients (MSK) for filter elements

The material gradient coefficients in psi/gpm apply to mineral oil (HLP) with a density of 0,876 kg/dm³ and a kinematic viscosity of 139 SUS (30 mm²/s). The pressure drop changes proportionally to the change in kinematic viscosity and density.

DUV	VG					G			P	API	
	3VG	6VG	10VG	16VG	25VG	25G	40G	80G	10P	10API	25API
2005	0.177	0.123	0.079	0.068	0.047	0.0059	0.0055	0.0038	0.041	0.040	0.018
3005	0.118	0.082	0.052	0.046	0.031	0.0040	0.0037	0.0025	0.027	0.027	0.012
4005	0.088	0.061	0.039	0.034	0.023	0.0030	0.0028	0.0019	0.020	0.020	0.009

$\Delta p = f(Q)$ – characteristics according to ISO 3968

The pressure drop characteristics apply to mineral oil (HLP) with a density of 0,876 kg/dm³. The pressure drop changes proportionally to the density.

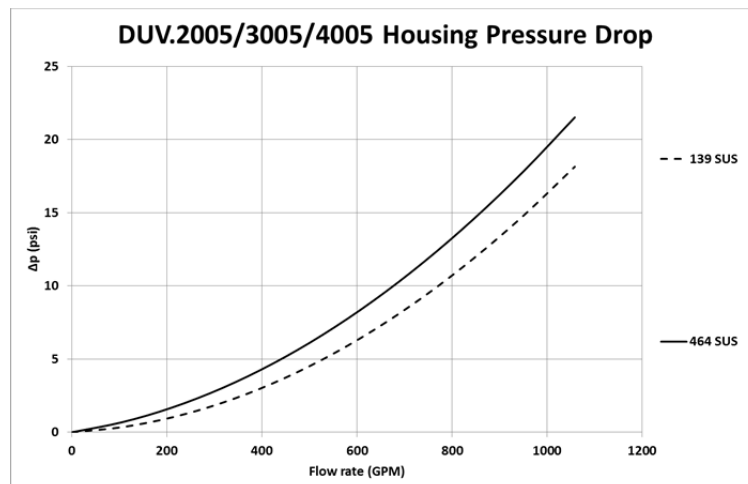

Symbols:

without indicator

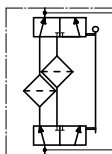

with by-pass valve

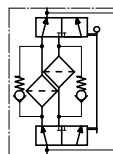

with electric indicator
AE 30 and AE 40

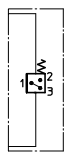

with visual-electric indicator
AE 50 and AE 62

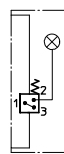

with visual-electric indicator
AE 70 and AE 80

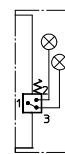

with visual indicator
OP/AOR/AOC

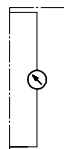

with visual-electrical indicator
OE

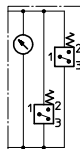

with electronic clogging sensor
VS5

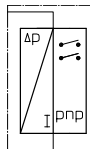

Spare parts:

item	qty.	designation	dimension and article-no. DUV 2005	dimension and article-no. DUV 3005	dimension and article-no. DUV 4005
1	2	filter element	01E.2001...	01E.3001...	01E.4001...
2	1	gasket kit of change over		5" 322726 (NBR)	322727 (FPM)
3	2	O-ring (DU 2005)		240 x 5 307592 (NBR)	328793 (FPM)
	4	O-ring (DU 3005/4005)			
4	2	O-ring		135 x 10 306016 (NBR)	307045 (FPM)
5	2	O-ring		125 x 10 304388 (NBR)	306006 (FPM)
6	2	O-ring		136,12 x 3,53 320162 (NBR)	320163 (FPM)
7	8	screw plug (DU 2005)		BSPP 1/4 304678	
	10	screw plug (DU 3005/4005)			
8	1	clogging indicator visual		AOR or AOC see seat-no. 1606	
9	1	clogging indicator visual-electric		OE see seat-no. 1628	
10	1	clogging indicator visual		OP see seat-no. 1628	
11	1	clogging indicator visual-electric		AE see seat-no. 1609	
12	1	clogging sensor electronic		VS5 see seat-no. 1641	
13	1	O-ring		15 x 1,5 315357 (NBR)	315427 (FPM)
14	1	O-ring		22 x 2 304708 (NBR)	304721 (FPM)
15	2	O-ring		14 x 2 304342 (NBR)	304722 (FPM)
16	2	screw plug		BSPP 1/4 305003	
17	1	pressure balance valve		3/8" 305000	

item 16 execution only without clogging indicator or clogging sensor

Test methods:

Filter elements are tested according to the following ISO standards:

ISO 2941	Verification of collapse/burst resistance
ISO 2942	Verification of fabrication integrity
ISO 2943	Verification of material compatibility with fluids
ISO 3723	Method for end load test
ISO 3724	Verification of flow fatigue characteristics
ISO 3968	Evaluation of pressure drop versus flow characteristics
ISO 16889	Multi-pass method for evaluating filtration performance