

Series DTEF 70

145 PSI

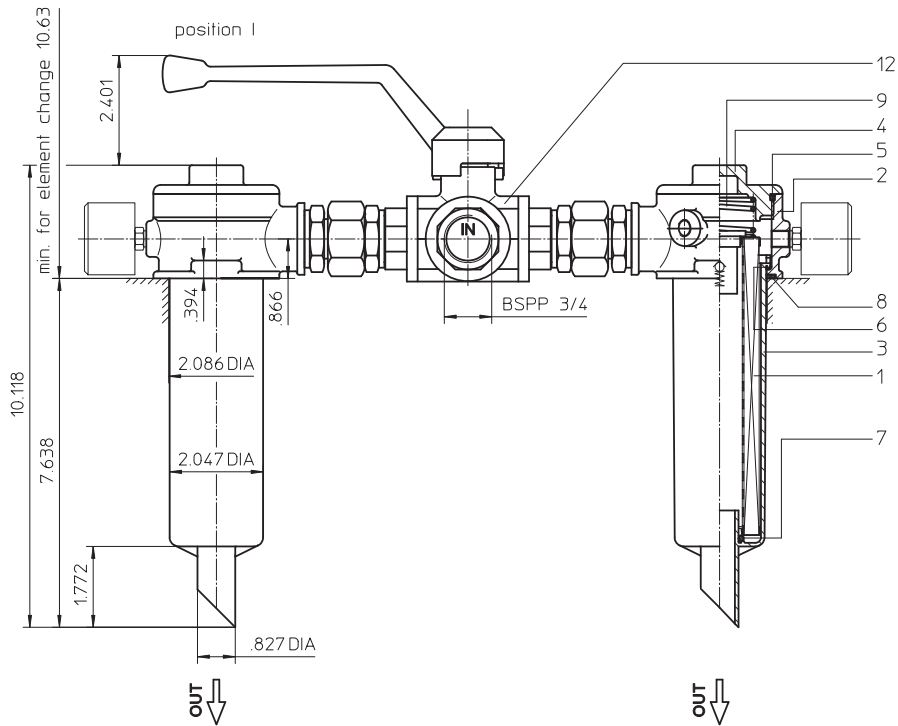
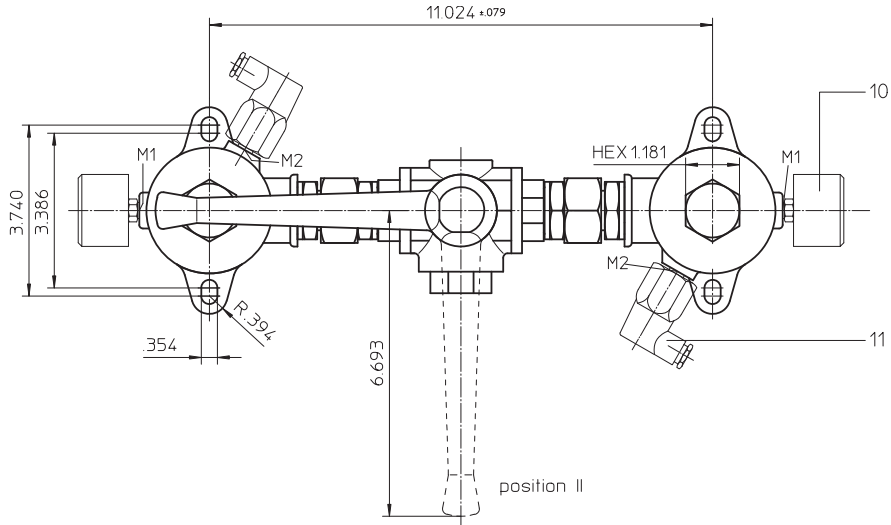

Position I: left filter-side in operation
 Position II: right filter-side in operation

Weight: approx. 8.0 lbs.

Dimensions: inches

Designs and performance values are subject to change.

Return Line Filter

Series DTEF 70

145 PSI

Description:

Return-line filter series DTEF 70 have a working pressure up to 145 PSI.

The DTEF-filters are directly mounted to the reservoir and connected to the return-line.

A three way changeover valve which is integrated in the middle of the housing makes it possible to switch from the dirty filter-side to the clean filter-side without interrupting operation. These filters can be installed as suction filters.

The filter element consists of star-shaped, pleated filter material, which is supported on the inside by a perforated core tube and is bonded to the end caps with a high-quality adhesive. The flow direction is from outside to inside.

Eaton filter elements are known for a high intrinsic stability and an excellent filtration capability, a high dirt-retaining capacity and a long service life.

For filtration finer than 40 µm use the disposable elements made of microglass. Filter elements as fine as 5 µm(c) are available; finer filter elements on request.

Eaton filter elements can be used for petroleum-based fluids, HW emulsions, water glycols, most synthetic fluids and lubrication fluids. Consult factory for specific fluid applications.

When changing the filter element, a detachable connection between the filter head and the filter bowl prevents dirty oil from flowing into the tank.

1. Type index:

1.1. Complete filter: (ordering example)

DTEF. 70. 10VG. 16. S. P. -. G. 4. -. O. E1

1	2	3	4	5	6	7	8	9	10	11	12
---	---	---	---	---	---	---	---	---	----	----	----

- | | |
|----|---|
| 1 | series:
DTEF = tank-mounted return-line-filter, change over |
| 2 | nominal size: 70 |
| 3 | filter-material and filter-fineness:
80G, 40G, 25G stainless steel wire mesh
25VG, 16VG, 10VG, 6VG, 3VG microglass
10P paper |
| 4 | filter element collapse rating:
16 = Δp 232 PSI |
| 5 | filter element design:
E = without by-pass valve
S = with by-pass valve Δp 29 PSI |
| 6 | sealing material:
P = Nitrile (NBR)
V = Viton (FPM) |
| 7 | filter element specification: (see catalog)
- = standard
VA = stainless steel
IS06 = for HFC application, see sheet-no. 31601 |
| 8 | process connection:
G = thread connection |
| 9 | process connection size:
4 = BSPP ¾ |
| 10 | filter housing specification: (see catalog)
- = standard
IS06 = for HFC application, see sheet-no. 31605 |
| 11 | clogging indicator at M1:
- = without
O = visual, see sheet-no. 1616
E1 = pressure switch, see sheet-no. 1616
E2 = pressure switch, see sheet-no. 1616
E5 = pressure switch, see sheet-no. 1616 |
| 12 | clogging indicator at M2:
possible indicators see position 11 of the type index |

To add an indicator to your filter, use the corresponding indicator data sheet to find the indicator details and add them to the filter assembly model code.

1.2. Filter element: (ordering example)

01E. 70. 10VG. 16. S. P. -

1	2	3	4	5	6	7
---	---	---	---	---	---	---

- | | |
|---|---|
| 1 | series:
01E. = filter element according to company standard |
| 2 | nominal size: 70 |
| 3 | - 7 see type index-complete filter |

Technical data:

design temperature:	14 °F to +212 °F
operating temperature:	14 °F to +176 °F
operating medium	mineral oil, other media on request
max. operating pressure:	145 PSI
opening pressure by-pass valve:	29 PSI
process connection:	thread connection
housing material standard:	Al-casting, glass fibre reinforced polyamide
sealing material:	Nitrile (NBR) or Viton (FPM), other materials on request
installation position:	vertical
volume tank:	2x .08 Gal.

Classified under the Pressure Equipment Directive 2014/68/EC for mineral oil (fluid group 2), Article 4, Para. 3.
Classified under ATEX Directive 2014/34/EC according to specific application (see questionnaire sheet-no. 34279-4).

Pressure drop flow curves:

Filter calculation/sizing

The pressure drop of the assembly at a given flow rate Q is the sum of the housing Δp and the element Δp and is calculated as follows:

$$\Delta p_{assembly} = \Delta p_{housing} + \Delta p_{element}$$

$$\Delta p_{housing} = (\text{see } \Delta p = f(Q) \text{ - characteristics})$$

$$\Delta p_{element} (PSI) = Q (GPM) \times \frac{MSK}{1000} \left(\frac{PSI}{GPM} \right) \times v (SUS) \times \frac{\rho}{0.876} \left(\frac{kg}{dm^3} \right)$$

For ease of calculation our Filter Selection tool is available online at www.eatonpowersource.com/calculators/filtration/

Material gradient coefficients (MSK) for filter elements

The material gradient coefficients in psi/gpm apply to mineral oil (HLP) with a density of 0.876 kg/dm³ and a kinematic viscosity of 139 SUS (30 mm²/s). The pressure drop changes proportionally to the change in kinematic viscosity and density.

DTEF	VG					G			P
	3VG	6VG	10VG	16VG	25VG	25G	40G	80G	10P
70	3.535	2.454	1.571	1.368	0.935	0.1196	0.1117	0.0765	0.797

$\Delta p = f(Q)$ – characteristics according to ISO 3968

The pressure drop characteristics apply to mineral oil (HLP) with a density of 0.876 kg/dm³. The pressure drop changes proportionally to the density.

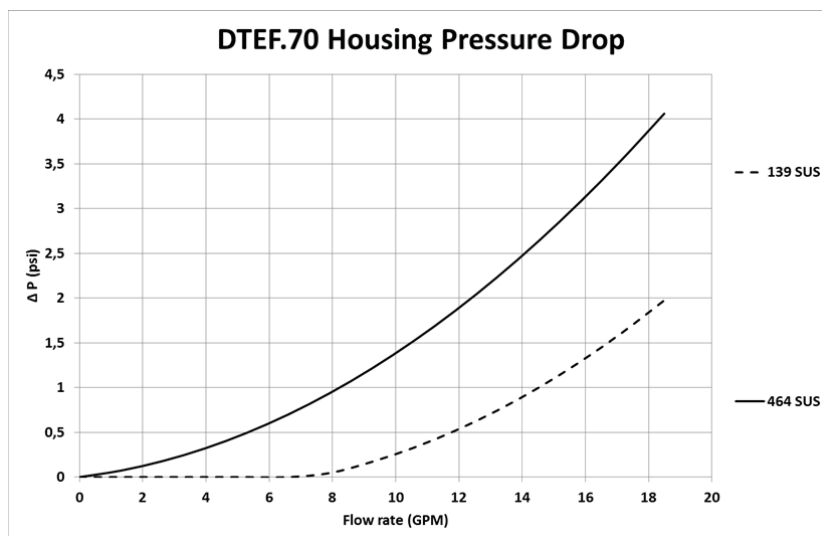

Symbols:

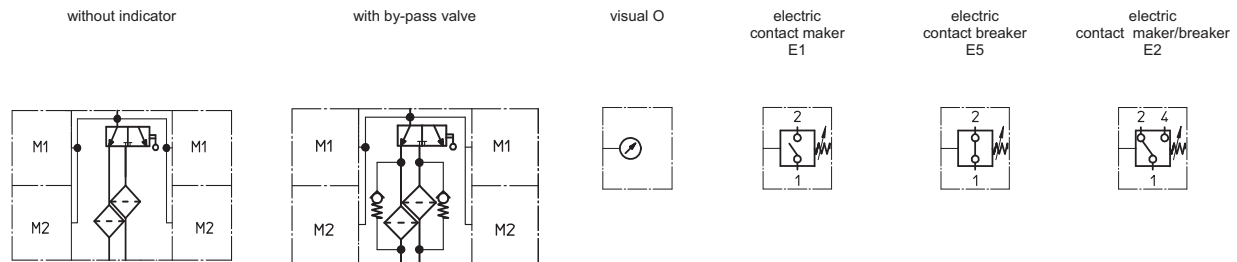

Spare parts:

item	qty.	designation	dimension	article-no.	
1	2	filter element	01.E70...	-	
2	2	filter head		305459	
3	2	filter bowl		304595	
4	2	screw plug	M 60 x 2	303621	
5	2	O-ring	56 x 3	305072 (NBR)	305322 (FPM)
6	2	O-ring	50 x 2,5	305239 (NBR)	305321 (FPM)
7	2	O-ring	22 x 3	304387 (NBR)	304931 (FPM)
8	4	O-ring	56 x 3	305072 (NBR)	305322 (FPM)
9	2	spring	DA = 40	304982	
10	2	clogging indicator, visual	O	see sheet-no. 1616	
11	2	pressure switch, electric	alternatively E1, E2 or E5	see sheet-no. 1616	
12	1	three-way-change-over valve		308115	

Test methods:

Filter elements are tested according to the following ISO standards:

ISO 2941	Verification of collapse/burst resistance
ISO 2942	Verification of fabrication integrity
ISO 2943	Verification of material compatibility with fluids
ISO 3723	Method for end load test
ISO 3724	Verification of flow fatigue characteristics
ISO 3968	Evaluation of pressure drop versus flow characteristics
ISO 16889	Multi-pass method for evaluating filtration performance

North America

44 Apple Street
Tinton Falls, NJ 07724
Toll Free: 800 656-3344
(North America only)
Tel: +1 732 212-4700

Europe/Africa/Middle East

Auf der Heide 2
53947 Nettersheim, Germany
Tel: +49 2486 809-0

Friedensstraße 41
68804 Altlußheim, Germany
Tel: +49 6205 2094-0

An den Nahewiesen 24
55450 Langenlonsheim, Germany
Tel: +49 6704 204-0

China

No. 3, Lane 280,
Linhong Road
Changning District, 200335
Shanghai, P.R. China
Tel: +86 21 5200-0099

Singapore

4 Loyang Lane #04-01/02
Singapore 508914
Tel: +65 6825-1668

Brazil

Av. Julia Gaioli, 474 – Bonsucesso
07251-500 – Guarulhos, Brazil
Tel: +55 11 2465-8822

For more information, please

email us at filtration@eaton.com
or visit www.eaton.com/filtration

© 2015 Eaton. All rights reserved. All trademarks and registered trademarks are the property of their respective owners. All information and recommendations appearing in this brochure concerning the use of products described herein are based on tests believed to be reliable. However, it is the user's responsibility to determine the suitability for his own use of such products. Since the actual use by others is beyond our control, no guarantee, expressed or implied, is made by Eaton as to the effects of such use or the results to be obtained. Eaton assumes no liability arising out of the use by others of such products. Nor is the information herein to be construed as absolutely complete, since additional information may be necessary or desirable when particular or exceptional conditions or circumstances exist or because of applicable laws or government regulations.

Series DTEF 120

145 PSI

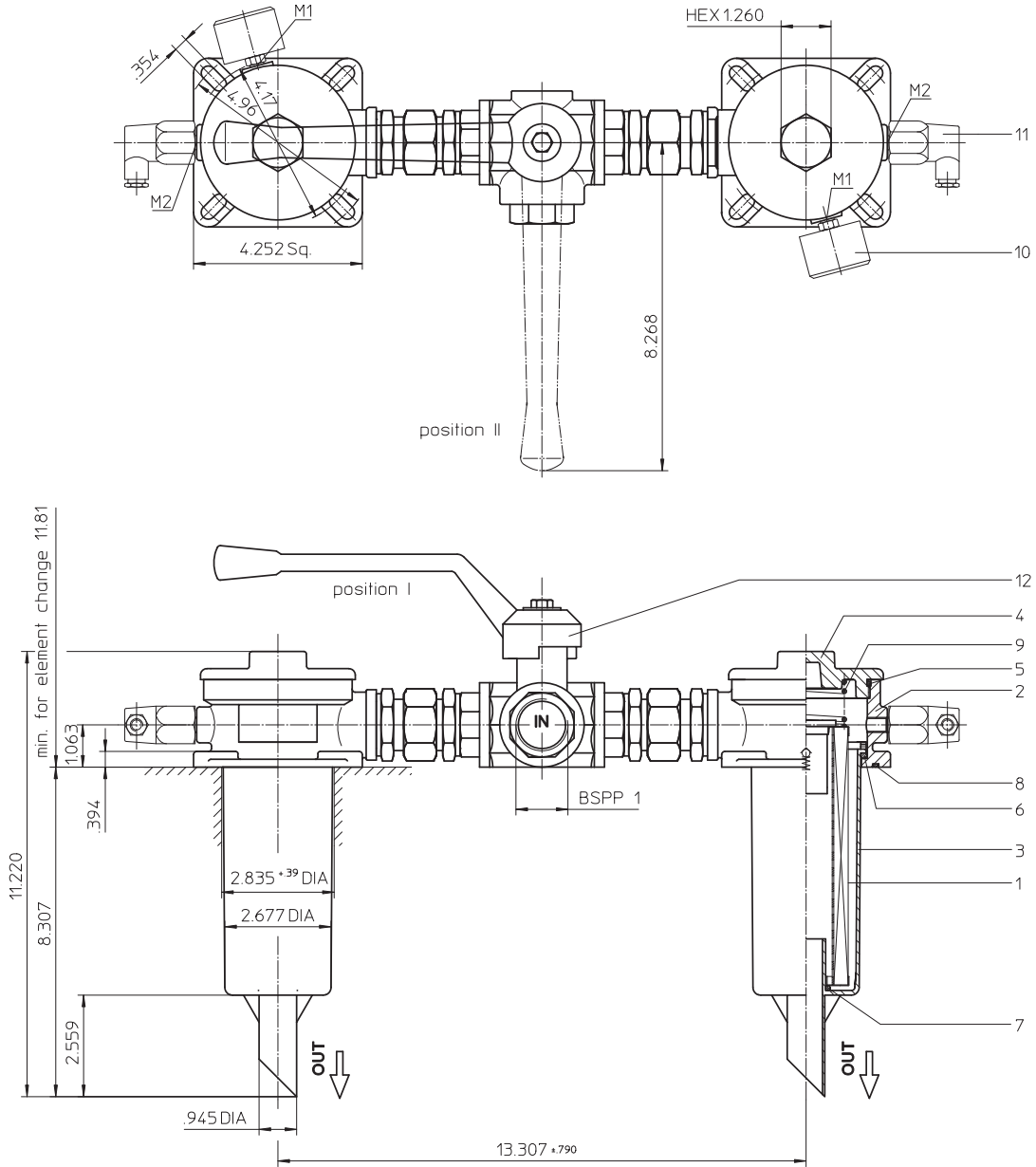

Position I: left filter-side in operation
 Position II: right filter-side in operation

Weight: approx. 13 lbs.

Dimensions: inches

Designs and performance values are subject to change.

Return Line Filter Series DTEF 120 145 PSI

Description:

Return-line filter series DTEF 120 have a working pressure up to 145 PSI.

The DTEF-filters are directly mounted to the reservoir and connected to the return-line.

A three way changeover valve which is integrated in the middle of the housing makes it possible to switch from the dirty filter-side to the clean filter-side without interrupting operation. These filters can be installed as suction filters.

The filter element consists of star-shaped, pleated filter material, which is supported on the inside by a perforated core tube and is bonded to the end caps with a high-quality adhesive. The flow direction is from outside to inside.

Eaton filter elements are known for a high intrinsic stability and an excellent filtration capability, a high dirt-retaining capacity and a long service life.

For filtration finer than 40 µm use the disposable elements made of microglass. Filter elements as fine as 5 µm(c) are available; finer filter elements on request.

Eaton filter elements can be used for petroleum-based fluids, HW emulsions, water glycols, most synthetic fluids and lubrication fluids. Consult factory for specific fluid applications.

When changing the filter element, a detachable connection between the filter head and the filter bowl prevents dirty oil from flowing into the tank.

1. Type index:

1.1. Complete filter: (ordering example)

DTEF. 120. 10VG. 16. S. P. -. G. 5. -. O. E1

1	2	3	4	5	6	7	8	9	10	11	12
---	---	---	---	---	---	---	---	---	----	----	----

- | | |
|----|---|
| 1 | series:
DTEF = tank-mounted return-line-filter, change over |
| 2 | nominal size: 120 |
| 3 | filter-material and filter-fineness:
80G, 40G, 25G stainless steel wire mesh
25VG, 16VG, 10VG, 6VG, 3VG microglass
10P paper |
| 4 | filter element collapse rating:
16 = Δp 232 PSI |
| 5 | filter element design:
E = without by-pass valve
S = with by-pass valve Δp 29 PSI |
| 6 | sealing material:
P = Nitrile (NBR)
V = Viton (FPM) |
| 7 | filter element specification: (see catalog)
- = standard
VA = stainless steel
IS06 = for HFC application, see sheet-no. 31601 |
| 8 | process connection:
G = thread connection |
| 9 | process connection size:
5 = BSPP 1 |
| 10 | filter housing specification: (see catalog)
- = standard
IS06 = for HFC application, see sheet-no. 31605 |
| 11 | clogging indicator at M1:
- = without
O = visual, see sheet-no. 1616
E1 = pressure switch, see sheet-no. 1616
E2 = pressure switch, see sheet-no. 1616
E5 = pressure switch, see sheet-no. 1616 |
| 12 | clogging indicator at M2:
possible indicators see position 11 of the type index |

To add an indicator to your filter, use the corresponding indicator data sheet to find the indicator details and add them to the filter assembly model code.

1.2. Filter element: (ordering example)

01E. 120. 10VG. 16. S. P. -

1	2	3	4	5	6	7
---	---	---	---	---	---	---

- | | |
|---|---|
| 1 | series:
01E. = filter element according to company standard |
| 2 | nominal size: 120 |
| 3 | - 7 see type index-complete filter |

Technical data:

design temperature:	14 °F to +212 °F
operating temperature:	14 °F to +176 °F
operating medium	mineral oil, other media on request
max. operating pressure:	145 PSI
opening pressure by-pass valve:	29 PSI
process connection:	thread connection
housing material standard:	Al-casting, glass fiber reinforced polyamide
sealing material:	Nitrile (NBR) or Viton (FPM), other materials on request
installation position:	vertical
volume tank:	2x .16 Gal.

Classified under the Pressure Equipment Directive 2014/68/EC for mineral oil (fluid group 2), Article 4, Para. 3.
Classified under ATEX Directive 2014/34/EC according to specific application (see questionnaire sheet-no. 34279-4).

Pressure drop flow curves:

Filter calculation/sizing

The pressure drop of the assembly at a given flow rate Q is the sum of the housing Δp and the element Δp and is calculated as follows:

$$\Delta p_{assembly} = \Delta p_{housing} + \Delta p_{element}$$

$$\Delta p_{housing} = (\text{see } \Delta p = f(Q) \text{ - characteristics})$$

$$\Delta p_{element} (PSI) = Q (GPM) \times \frac{MSK}{1000} \left(\frac{PSI}{GPM} \right) \times \nu (SUS) \times \frac{\rho}{0.876} \left(\frac{kg}{dm^3} \right)$$

For ease of calculation our Filter Selection tool is available online at www.eatonpowersource.com/calculators/filtration/

Material gradient coefficients (MSK) for filter elements

The material gradient coefficients in psi/gpm apply to mineral oil (HLP) with a density of 0.876 kg/dm³ and a kinematic viscosity of 139 SUS (30 mm²/s). The pressure drop changes proportionally to the change in kinematic viscosity and density.

DTEF	VG					G			P
	3VG	6VG	10VG	16VG	25VG	25G	40G	80G	10P
120	3.162	2.195	1.405	1.224	0.836	0.1144	0.1068	0.0731	0.690

$\Delta p = f(Q)$ – characteristics according to ISO 3968

The pressure drop characteristics apply to mineral oil (HLP) with a density of 0.876 kg/dm³. The pressure drop changes proportionally to the density.

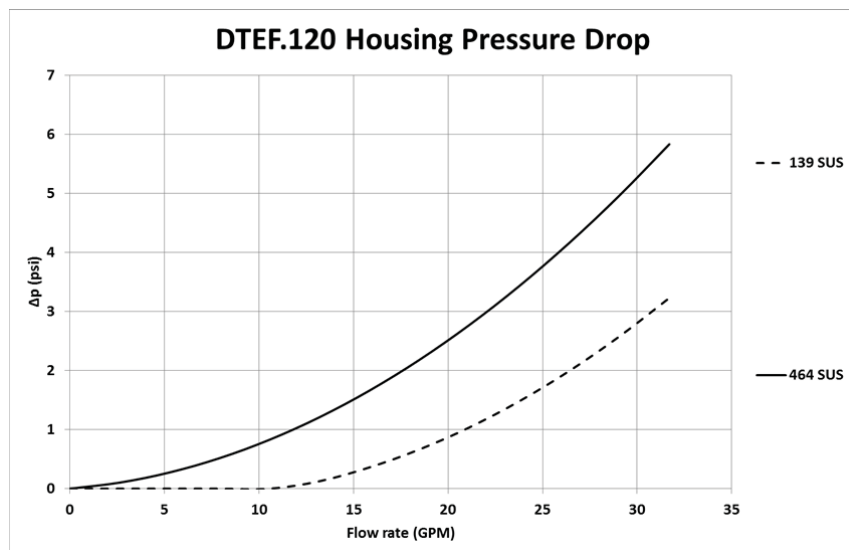

Symbols:

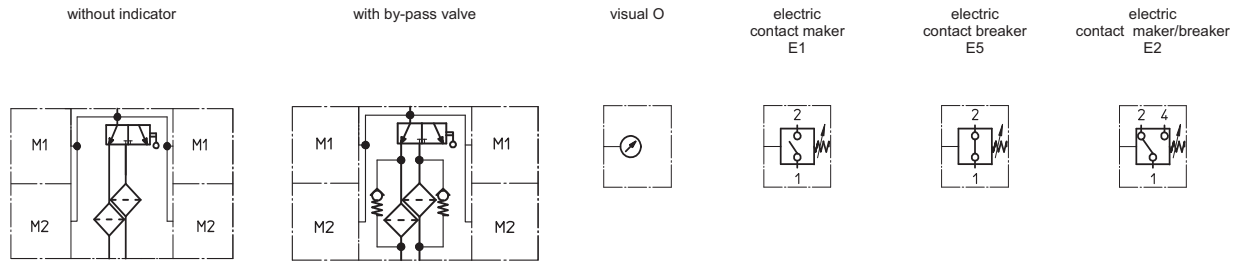

Spare parts:

item	qty.	designation	dimension	article-no.
1	2	filter element	01.E120...	
2	2	filter head		305467
3	2	filter bowl		303041
4	2	screw plug	M 60 x 2	302069
5	2	O-ring	75 x 3	302215 (NBR) 304729 (FPM)
6	2	O-ring	68 x 4	303037 (NBR) 313046 (FPM)
7	2	O-ring	24 x 3	303038 (NBR) 304397 (FPM)
8	4	O-ring	86 x 3	305470 (NBR) 313047 (FPM)
9	2	spring	DA = 52	302144
10	2	clogging indicator, visual	O	see sheet-no. 1616
11	2	pressure switch, electric	alternatively E1, E2 or E5	see sheet-no. 1616
12	1	three-way-change-over valve		308123

Test methods:

Filter elements are tested according to the following ISO standards:

ISO 2941	Verification of collapse/burst resistance
ISO 2942	Verification of fabrication integrity
ISO 2943	Verification of material compatibility with fluids
ISO 3723	Method for end load test
ISO 3724	Verification of flow fatigue characteristics
ISO 3968	Evaluation of pressure drop versus flow characteristics
ISO 16889	Multi-pass method for evaluating filtration performance

North America

44 Apple Street
Tinton Falls, NJ 07724
Toll Free: 800 656-3344
(North America only)
Tel: +1 732 212-4700

Europe/Africa/Middle East

Auf der Heide 2
53947 Nettersheim, Germany
Tel: +49 2486 809-0

Friedensstraße 41
68804 Altlufsheim, Germany
Tel: +49 6205 2094-0

An den Nahewiesen 24
55450 Langenlonsheim, Germany
Tel: +49 6704 204-0

China

No. 3, Lane 280,
Linhong Road
Changning District, 200335
Shanghai, P.R. China
Tel: +86 21 5200-0099

Singapore

4 Loyang Lane #04-01/02
Singapore 508914
Tel: +65 6825-1668

Brazil

Av. Julia Gaioli, 474 – Bonsucesso
07251-500 – Guarulhos, Brazil
Tel: +55 11 2465-8822

For more information, please

email us at filtration@eaton.com
or visit www.eaton.com/filtration

© 2015 Eaton. All rights reserved. All trademarks and registered trademarks are the property of their respective owners. All information and recommendations appearing in this brochure concerning the use of products described herein are based on tests believed to be reliable. However, it is the user's responsibility to determine the suitability for his own use of such products. Since the actual use by others is beyond our control, no guarantee, expressed or implied, is made by Eaton as to the effects of such use or the results to be obtained. Eaton assumes no liability arising out of the use by others of such products. Nor is the information herein to be construed as absolutely complete, since additional information may be necessary or desirable when particular or exceptional conditions or circumstances exist or because of applicable laws or government regulations.

Series DTEF 320

145 PSI

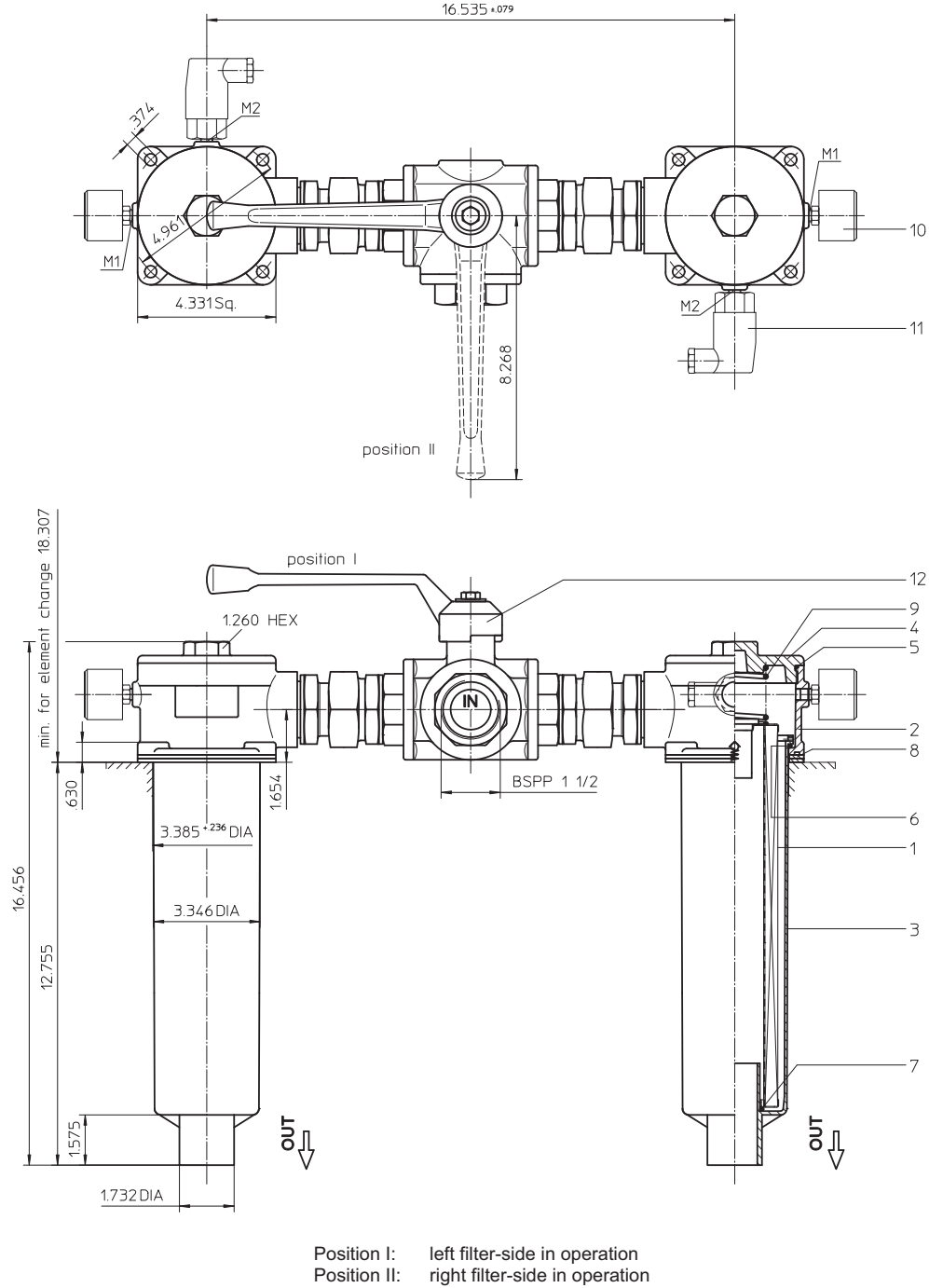

Weight: approx. 22 lbs.

Dimensions: inches

Designs and performance values are subject to change.



Powering Business Worldwide

Return Line Filter Series DTEF 320 145 PSI

Description:

Return-line filter series DTEF 320 have a working pressure up to 145 PSI.

The DTEF-filters are directly mounted to the reservoir and connected to the return-line.

A three way changeover valve which is integrated in the middle of the housing makes it possible to switch from the dirty filter-side to the clean filter-side without interrupting operation. These filters can be installed as suction filters.

The filter element consists of star-shaped, pleated filter material, which is supported on the inside by a perforated core tube and is bonded to the end caps with a high-quality adhesive. The flow direction is from outside to inside.

Eaton filter elements are known for a high intrinsic stability and an excellent filtration capability, a high dirt-retaining capacity and a long service life.

For filtration finer than 40 µm use the disposable elements made of microglass. Filter elements as fine as 5 µm(c) are available; finer filter elements on request.

Eaton filter elements can be used for petroleum-based fluids, HW emulsions, water glycols, most synthetic fluids and lubrication fluids. Consult factory for specific fluid applications.

When changing the filter element, a detachable connection between the filter head and the filter bowl prevents dirty oil from flowing into the tank.

1. Type index:

1.1. Complete filter: (ordering example)

DTEF. 320. 10VG. 16. S. P. - . G. 7. - . O. E1

1	2	3	4	5	6	7	8	9	10	11	12
---	---	---	---	---	---	---	---	---	----	----	----

- | | |
|----|---|
| 1 | series:
DTEF = tank-mounted return-line-filter, change over |
| 2 | nominal size: 320 |
| 3 | filter-material and filter-fineness:
80G, 40G, 25G stainless steel wire mesh
25VG, 16VG, 10VG, 6VG, 3VG microglass
10P paper |
| 4 | filter element collapse rating:
16 = Δp 232 PSI |
| 5 | filter element design:
E = without by-pass valve
S = with by-pass valve Δp 29 PSI |
| 6 | sealing material:
P = Nitrile (NBR)
V = Viton (FPM) |
| 7 | filter element specification: (see catalog)
- = standard
VA = stainless steel
IS06 = for HFC application, see sheet-no. 31601 |
| 8 | process connection:
G = thread connection |
| 9 | process connection size:
7 = BSPP 1 ½ |
| 10 | filter housing specification: (see catalog)
- = standard
IS06 = for HFC application, see sheet-no. 31605 |
| 11 | clogging indicator at M1:
- = without
O = visual, see sheet-no. 1616
E1 = pressure switch, see sheet-no. 1616
E2 = pressure switch, see sheet-no. 1616
E5 = pressure switch, see sheet-no. 1616 |
| 12 | clogging indicator at M2:
possible indicators see position 11 of the type index |

To add an indicator to your filter, use the corresponding indicator data sheet to find the indicator details and add them to the filter assembly model code.

1.2. Filter element: (ordering example)

01E. 320. 10VG. 16. S. P. -

1	2	3	4	5	6	7
---	---	---	---	---	---	---

- | | |
|---|---|
| 1 | series:
01E. = filter element according to company standard |
| 2 | nominal size: 320 |
| 3 | - 7 see type index-complete filter |

Technical data:

design temperature:	14 °F to +212 °F
operating temperature:	14 °F to +176 °F
operating medium	mineral oil, other media on request
max. operating pressure:	145 PSI
opening pressure by-pass valve:	29 PSI
process connection:	thread connection
housing material standard:	Al-casting, glass fibre reinforced polyamide
sealing material:	Nitrile (NBR) or Viton (FPM), other materials on request
installation position:	vertical
volume tank:	2x .48 Gal.

Classified under the Pressure Equipment Directive 2014/68/EC for mineral oil (fluid group 2), Article 4, Para. 3.
Classified under ATEX Directive 2014/34/EC according to specific application (see questionnaire sheet-no. 34279-4).

Pressure drop flow curves:

Filter calculation/sizing

The pressure drop of the assembly at a given flow rate Q is the sum of the housing Δp and the element Δp and is calculated as follows:

$$\Delta p_{assembly} = \Delta p_{housing} + \Delta p_{element}$$

$$\Delta p_{housing} = (\text{see } \Delta p = f(Q) \text{ - characteristics})$$

$$\Delta p_{element} (PSI) = Q (GPM) \times \frac{MSK}{1000} \left(\frac{PSI}{GPM} \right) \times \nu (SUS) \times \frac{\rho}{0.876} \left(\frac{kg}{dm^3} \right)$$

For ease of calculation our Filter Selection tool is available online at www.eatonpowersource.com/calculators/filtration/

Material gradient coefficients (MSK) for filter elements

The material gradient coefficients in psi/gpm apply to mineral oil (HLP) with a density of 0.876 kg/dm³ and a kinematic viscosity of 139 SUS (30 mm²/s). The pressure drop changes proportionally to the change in kinematic viscosity and density.

DTEF	VG					G			P
	3VG	6VG	10VG	16VG	25VG	25G	40G	80G	10P
320	1.148	0.797	0.510	0.444	0.304	0.0337	0.0314	0.0215	0.253

$\Delta p = f(Q)$ – characteristics according to ISO 3968

The pressure drop characteristics apply to mineral oil (HLP) with a density of 0.876 kg/dm³. The pressure drop changes proportionally to the density.

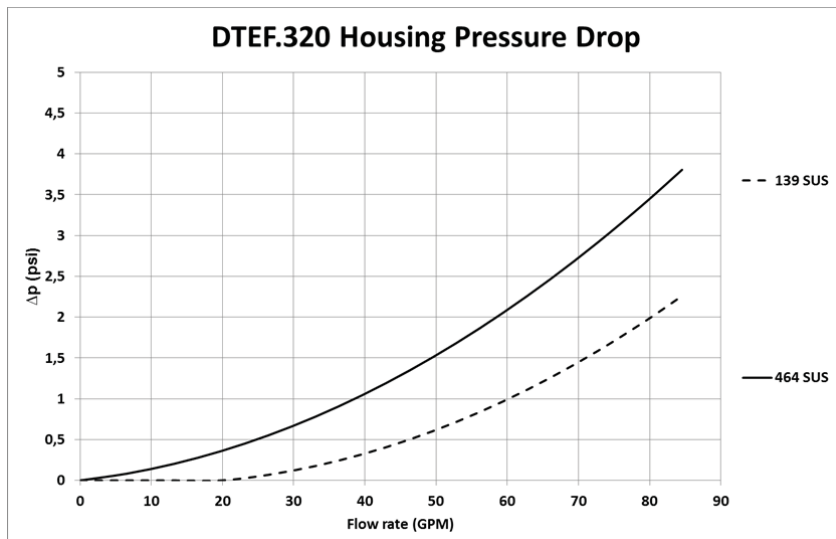

Symbols:

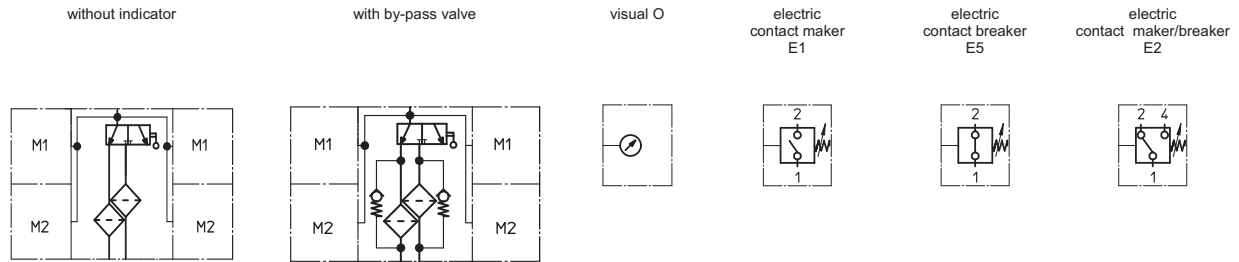

Spare parts:

item	qty.	designation	dimension	article-no.	
1	2	filter element	01.E320...		
2	2	filter head		305475	
3	2	filter bowl		302145	
4	2	screw plug	M 100 x 2	302338	
5	2	O-ring	96 x 3	305292 (NBR)	305297 (FPM)
6	2	O-ring	82 x 3	305191 (NBR)	305298 (FPM)
7	2	O-ring	40 x 3	304389 (NBR)	304391 (FPM)
8	4	gasket	110 x 110 x 3	304456 (NBR)	314138 (FPM)
9	2	spring	DA = 52	305053	
10	2	clogging indicator, visual	O	see sheet-no. 1616	
11	2	pressure switch, electric	alternatively E1, E2 or E5	see sheet-no. 1616	
12	1	three-way-change-over valve		308128	

Test methods:

Filter elements are tested according to the following ISO standards:

ISO 2941	Verification of collapse/burst resistance
ISO 2942	Verification of fabrication integrity
ISO 2943	Verification of material compatibility with fluids
ISO 3723	Method for end load test
ISO 3724	Verification of flow fatigue characteristics
ISO 3968	Evaluation of pressure drop versus flow characteristics
ISO 16889	Multi-pass method for evaluating filtration performance



North America
44 Apple Street
Tinton Falls, NJ 07724
Toll Free: 800 656-3344
(North America only)
Tel: +1 732 212-4700

Europe/Africa/Middle East
Auf der Heide 2
53947 Nettersheim, Germany
Tel: +49 2486 809-0

Friedensstraße 41
68804 Altludersheim, Germany
Tel: +49 6205 2094-0

An den Nahewiesen 24
55450 Langenlonsheim, Germany
Tel: +49 6704 204-0

China
No. 3, Lane 280,
Linhong Road
Changning District, 200335
Shanghai, P.R. China
Tel: +86 21 5200-0099

Singapore
4 Loyang Lane #04-01/02
Singapore 508914
Tel: +65 6825-1668

Brazil
Av. Julia Gaioli, 474 – Bonsucesso
07251-500 – Guarulhos, Brazil
Tel: +55 11 2465-8822

**For more information, please
email us at filtration@eaton.com
or visit www.eaton.com/filtration**

© 2015 Eaton. All rights reserved. All trademarks and registered trademarks are the property of their respective owners. All information and recommendations appearing in this brochure concerning the use of products described herein are based on tests believed to be reliable. However, it is the user's responsibility to determine the suitability for his own use of such products. Since the actual use by others is beyond our control, no guarantee, expressed or implied, is made by Eaton as to the effects of such use or the results to be obtained. Eaton assumes no liability arising out of the use by others of such products. Nor is the information herein to be construed as absolutely complete, since additional information may be necessary or desirable when particular or exceptional conditions or circumstances exist or because of applicable laws or government regulations.

Series DTEF 426

145 PSI

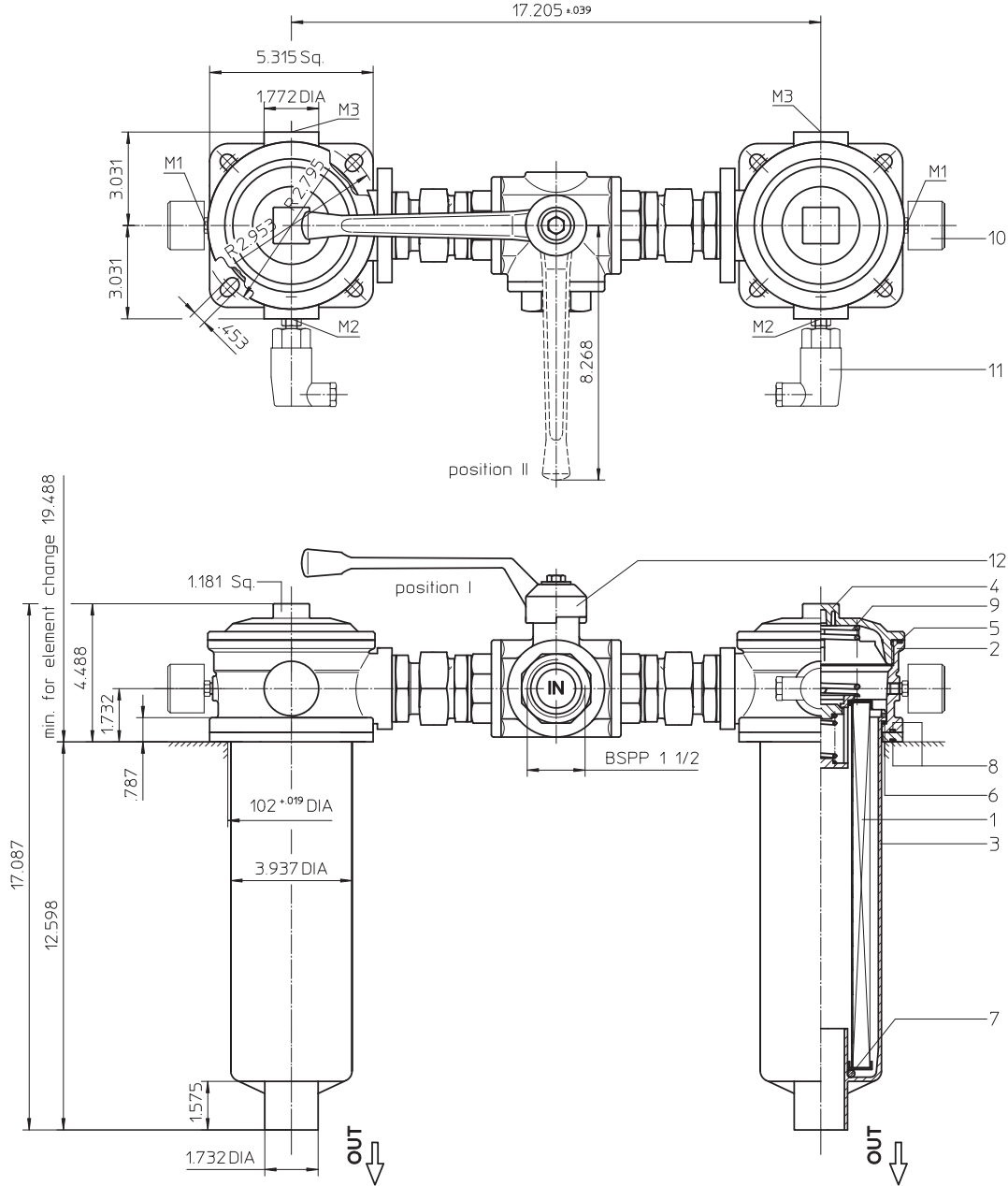

Position I: left filter-side in operation
 Position II: right filter-side in operation

Weight: approx. 27.5 lbs.

Dimensions: inches

Designs and performance values are subject to change.

Return Line Filter Series DTEF 426 145 PSI

Description:

Return-line filter series DTEF 426 have a working pressure up to 145 PSI.

The DTEF-filters are directly mounted to the reservoir and connected to the return-line.

A three way changeover valve which is integrated in the middle of the housing makes it possible to switch from the dirty filter-side to the clean filter-side without interrupting operation. These filters can be installed as suction filters.

The filter element consists of star-shaped, pleated filter material, which is supported on the inside by a perforated core tube and is bonded to the end caps with a high-quality adhesive. The flow direction is from outside to inside.

Eaton filter elements are known for a high intrinsic stability and an excellent filtration capability, a high dirt-retaining capacity and a long service life.

For filtration finer than 40 µm use the disposable elements made of microglass. Filter elements as fine as 5 µm(c) are available; finer filter elements on request.

Eaton filter elements can be used for petroleum-based fluids, HW emulsions, water glycols, most synthetic fluids and lubrication fluids. Consult factory for specific fluid applications.

When changing the filter element, a detachable connection between the filter head and the filter bowl prevents dirty oil from flowing into the tank.

1. Type index:

1.1. Complete filter: (ordering example)

DTEF. 426. 10VG. 16. S. P. -. G. 7. -. O. E1. -

1	2	3	4	5	6	7	8	9	10	11	12	13
---	---	---	---	---	---	---	---	---	----	----	----	----

- 1 | **series:**
DTEF = tank-mounted return-line-filter, change over
- 2 | **nominal size:** 426
- 3 | **filter-material and filter-fineness:**
80G, 40G, 25G stainless steel wire mesh
25VG, 16VG, 10VG, 6VG, 3VG microglass
10P paper
- 4 | **filter element collapse rating:**
16 = Δp 232 PSI
- 5 | **filter element design:**
E = without by-pass valve
S = with by-pass valve Δp 29 PSI
- 6 | **sealing material:**
P = Nitrile (NBR)
V = Viton (FPM)
- 7 | **filter element specification:** (see catalog)
- = standard
VA = stainless steel
IS06 = for HFC application, see sheet-no. 31601
- 8 | **process connection:**
G = thread connection
- 9 | **process connection size:**
7 = BSPP 1 ½
- 10 | **filter housing specification:** (see catalog)
- = standard
IS06 = for HFC application, see sheet-no. 31605
- 11 | **clogging indicator at M1:**
- = without
O = visual, see sheet-no. 1616
E1 = pressure switch, see sheet-no. 1616
E2 = pressure switch, see sheet-no. 1616
E5 = pressure switch, see sheet-no. 1616
- 12 | **clogging indicator at M2:**
possible indicators see position 11 of the type index
- 13 | **clogging indicator at M3:**
possible indicators see position 11 of the type index

To add an indicator to your filter, use the corresponding indicator data sheet to find the indicator details and add them to the filter assembly model code.

1.2. Filter element: (ordering example)

01E. 425. 10VG. 16. S. P. -

1	2	3	4	5	6	7
---	---	---	---	---	---	---

- 1 | **series:**
01E. = filter element according to company standard
- 2 | **nominal size:** 425
- 3 | - 7 | see type index-complete filter

Technical data:

design temperature:	14 °F to +212 °F
operating temperature:	14 °F to +176 °F
operating medium	mineral oil, other media on request
max. operating pressure:	145 PSI
opening pressure by-pass valve:	29 PSI
process connection:	thread connection
housing material standard:	Al-casting, glass fibre reinforced polyamide
sealing material:	Nitrile (NBR) or Viton (FPM), other materials on request
installation position:	vertical
volume tank:	2x .70 Gal.

Classified under the Pressure Equipment Directive 2014/68/EC for mineral oil (fluid group 2), Article 4, Para. 3.
Classified under ATEX Directive 2014/34/EC according to specific application (see questionnaire sheet-no. 34279-4).

Pressure drop flow curves:

Filter calculation/sizing

The pressure drop of the assembly at a given flow rate Q is the sum of the housing Δp and the element Δp and is calculated as follows:

$$\Delta p_{assembly} = \Delta p_{housing} + \Delta p_{element}$$

$$\Delta p_{housing} = (\text{see } \Delta p = f(Q) \text{ - characteristics})$$

$$\Delta p_{element} (PSI) = Q (GPM) \times \frac{MSK}{1000} \left(\frac{PSI}{GPM} \right) \times \nu (SUS) \times \frac{\rho}{0.876} \left(\frac{kg}{dm^3} \right)$$

For ease of calculation our Filter Selection tool is available online at www.eatonpowersource.com/calculators/filtration/

Material gradient coefficients (MSK) for filter elements

The material gradient coefficients in psi/gpm apply to mineral oil (HLP) with a density of 0.876 kg/dm³ and a kinematic viscosity of 139 SUS (30 mm²/s). The pressure drop changes proportionally to the change in kinematic viscosity and density.

DTEF	VG					G			P
	3VG	6VG	10VG	16VG	25VG	25G	40G	80G	10P
426	0.849	0.589	0.377	0.328	0.224	0.0270	0.0252	0.0172	0.182

$\Delta p = f(Q)$ – characteristics according to ISO 3968

The pressure drop characteristics apply to mineral oil (HLP) with a density of 0.876 kg/dm³. The pressure drop changes proportionally to the density.

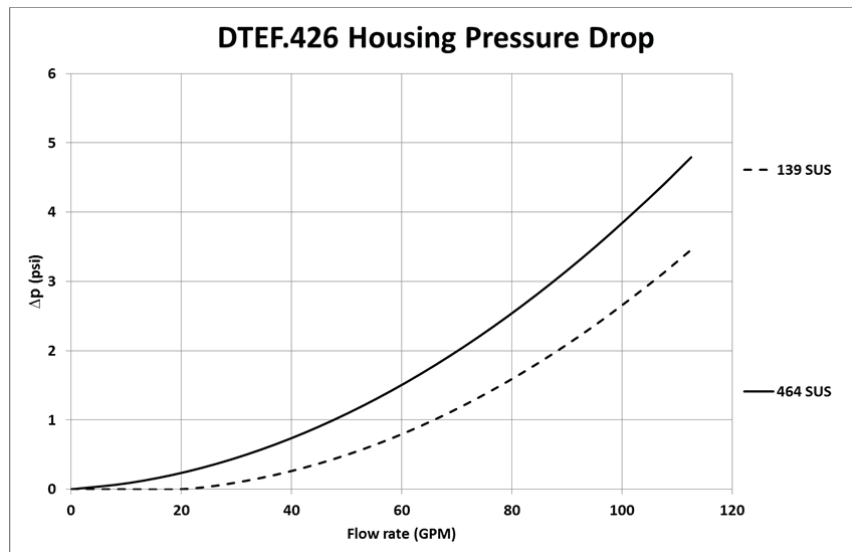

Symbols:

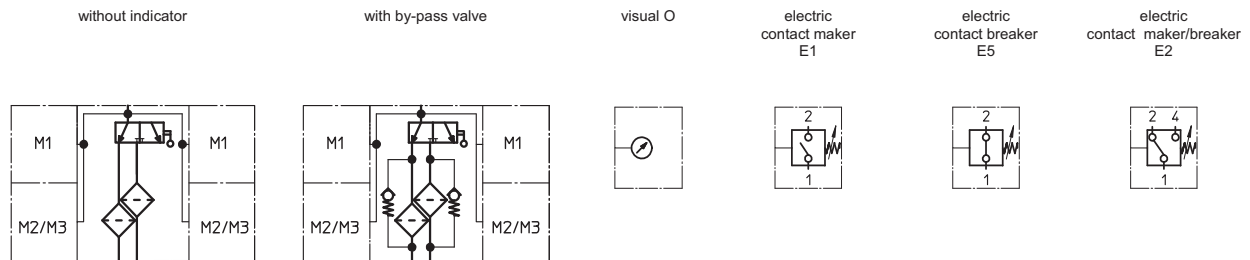

Spare parts:

item	qty.	designation	dimension	article-no.
1	2	filter element	01.E425...	
2	2	filter head		313434
3	2	filter bowl		303732
4	2	screw plug	M 120 x 3	313649
5	2	O-ring	128 x 3	304602 (NBR) 308140 (FPM)
6	2	O-ring	98 x 4	301914 (NBR) 304765 (FPM)
7	2	O-ring	44 x 6	302222 (NBR) 304384 (FPM)
8	4	O-ring	115 x 3	303963 (NBR) 307762 (FPM)
9	2	spring	DA = 63,5	304983
10	2	clogging indicator, visual	O	see sheet-no. 1616
11	2	pressure switch, electric	alternatively E1, E2 or E5	see sheet-no. 1616
12	1	three-way-change-over valve		308128

Test methods:

Filter elements are tested according to the following ISO standards:

ISO 2941	Verification of collapse/burst resistance
ISO 2942	Verification of fabrication integrity
ISO 2943	Verification of material compatibility with fluids
ISO 3723	Method for end load test
ISO 3724	Verification of flow fatigue characteristics
ISO 3968	Evaluation of pressure drop versus flow characteristics
ISO 16889	Multi-pass method for evaluating filtration performance



North America
 44 Apple Street
 Tinton Falls, NJ 07724
 Toll Free: 800 656-3344
 (North America only)
 Tel: +1 732 212-4700

Europe/Africa/Middle East
 Auf der Heide 2
 53947 Nettersheim, Germany
 Tel: +49 2486 809-0

Friedensstraße 41
 68804 Altlußheim, Germany
 Tel: +49 6205 2094-0

An den Nahewiesen 24
 55450 Langenlonsheim, Germany
 Tel: +49 6704 204-0

China
 No. 3, Lane 280,
 Linhong Road
 Changning District, 200335
 Shanghai, P.R. China
 Tel: +86 21 5200-0099

Singapore
 4 Loyang Lane #04-01/02
 Singapore 508914
 Tel: +65 6825-1668

Brazil
 Av. Julia Gaioli, 474 – Bonsucesso
 07251-500 – Guarulhos, Brazil
 Tel: +55 11 2465-8822

**For more information, please
 email us at filtration@eaton.com
 or visit www.eaton.com/filtration**

© 2015 Eaton. All rights reserved. All trademarks and registered trademarks are the property of their respective owners. All information and recommendations appearing in this brochure concerning the use of products described herein are based on tests believed to be reliable. However, it is the user's responsibility to determine the suitability for his own use of such products. Since the actual use by others is beyond our control, no guarantee, expressed or implied, is made by Eaton as to the effects of such use or the results to be obtained. Eaton assumes no liability arising out of the use by others of such products. Nor is the information herein to be construed as absolutely complete, since additional information may be necessary or desirable when particular or exceptional conditions or circumstances exist or because of applicable laws or government regulations.

Series DTEF 625

145 PSI

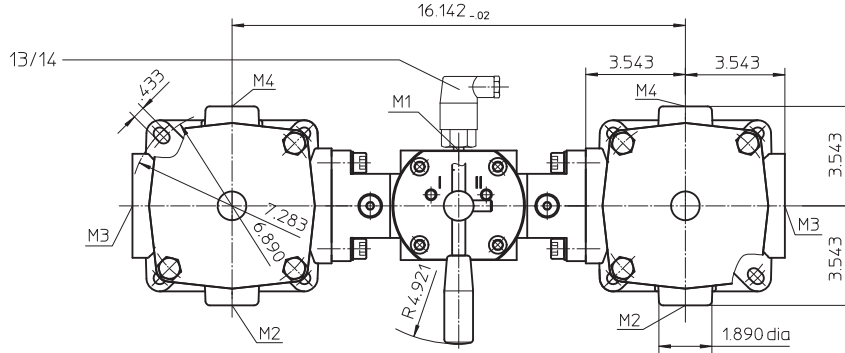

1) min. for element change without discharge pipe 20.47
 min. for element change with discharge pipe 26.97

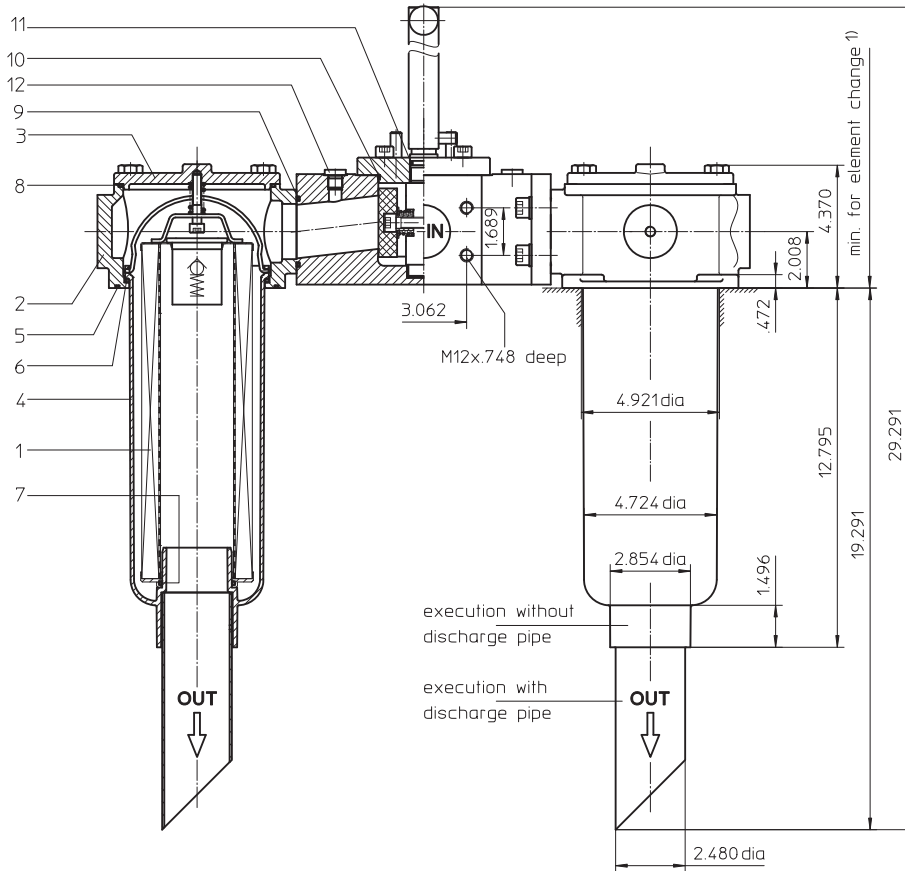

Position I: left filter-side in operation
 Position II: right filter-side in operation

Weight: approx. 33 lbs.

Dimensions: inches

Designs and performance values are subject to change.

Return Line Filter Series DTEF 625 145 PSI

Description:

Return-line filter series DTEF 625 have a working pressure up to 145 PSI.

The DTEF-filters are directly mounted to the reservoir and connected to the return-line.

A rotary slide valve which is integrated in the middle of the housing makes it possible to switch from the dirty filter-side to the clean filter-side without interrupting operation. These filters can be installed as suction filters.

The filter element consists of star-shaped, pleated filter material, which is supported on the inside by a perforated core tube and is bonded to the end caps with a high-quality adhesive. The flow direction is from outside to inside.

Eaton filter elements are known for a high intrinsic stability and an excellent filtration capability, a high dirt-retaining capacity and a long service life.

For filtration finer than 40 µm use the disposable elements made of microglass. Filter elements as fine as 5 µm(c) are available; finer filter elements on request.

Eaton filter elements can be used for petroleum-based fluids, HW emulsions, water glycols, most synthetic fluids and lubrication fluids. Consult factory for specific fluid applications.

When changing the filter element, a detachable connection between the filter head and the filter bowl prevents dirty oil from flowing into the tank.

1. Type index:

1.1. Complete filter: (ordering example)

DTEF. 625. 10VG. 16. S. P. - . FS. 8. - . E1. - . - . -

1	2	3	4	5	6	7	8	9	10	11	12	13	14	15
---	---	---	---	---	---	---	---	---	----	----	----	----	----	----

- | | |
|----|---|
| 1 | series:
DTEF = tank-mounted return-line-filter, change over |
| 2 | nominal size: 625 |
| 3 | filter-material and filter-fineness:
80G, 40G, 25G stainless steel wire mesh
25VG, 16VG, 10VG, 6VG, 3VG microglass
10P paper |
| 4 | filter element collapse rating:
16 = Δp 232 PSI |
| 5 | filter element design:
E = without by-pass valve
S = with by-pass valve Δp 29 PSI |
| 6 | sealing material:
P = Nitrile (NBR)
V = Viton (FPM) |
| 7 | filter element specification: (see catalog)
- = standard
VA = stainless steel
IS06 = for HFC application, see sheet-no. 31601 |
| 8 | process connection:
FS = SAE-flange 3000 PSI |
| 9 | process connection size:
8 = 2" |
| 10 | filter housing specification: (see catalog)
- = standard
IS06 = for HFC application, see sheet-no. 31605 |
| 11 | clogging indicator at M1:
- = without
O = visual, see sheet-no. 1616
E1 = pressure switch, see sheet-no. 1616
E2 = pressure switch, see sheet-no. 1616
E5 = pressure switch, see sheet-no. 1616 |
| 12 | clogging indicator at M2:
possible indicators see position 11 of the type index |
| 13 | clogging indicator at M3:
possible indicators see position 11 of the type index |
| 14 | clogging indicator at M4:
possible indicators see position 11 of the type index |
| 15 | discharge pipe:
- = without
1 = with discharge pipe |

To add an indicator to your filter, use the corresponding indicator data sheet to find the indicator details and add them to the filter assembly model code.

1.2. Filter element: (ordering example)

01E. 631. 10VG. 16. S. P. -

1	2	3	4	5	6	7
---	---	---	---	---	---	---

- | | |
|---|---|
| 1 | series:
01E. = filter element according to company standard |
| 2 | nominal size: 631 |
| 3 | - 7 see type index-complete filter |

Technical data:

design temperature:	14 °F to +212 °F
operating temperature:	14 °F to +176 °F
operating medium	mineral oil, other media on request
max. operating pressure:	145 PSI
opening pressure by-pass valve:	29 PSI
process connection:	SAE-flange 3000 PSI
housing material standard:	Al-casting, C-steel
sealing material:	Nitrile (NBR) or Viton (FPM), other materials on request
installation position:	vertical
volume tank:	2x 1.0 Gal.

Classified under the Pressure Equipment Directive 2014/68/EC for mineral oil (fluid group 2), Article 4, Para. 3.
 Classified under ATEX Directive 2014/34/EC according to specific application (see questionnaire sheet-no. 34279-4).

Pressure drop flow curves:

Filter calculation/sizing

The pressure drop of the assembly at a given flow rate Q is the sum of the housing Δp and the element Δp and is calculated as follows:

$$\Delta p_{assembly} = \Delta p_{housing} + \Delta p_{element}$$

$$\Delta p_{housing} = (\text{see } \Delta p = f(Q) \text{ - characteristics})$$

$$\Delta p_{element} (PSI) = Q (GPM) \times \frac{MSK}{1000} \left(\frac{PSI}{GPM} \right) \times \nu (SUS) \times \frac{\rho}{0.876} \left(\frac{kg}{dm^3} \right)$$

For ease of calculation our Filter Selection tool is available online at www.eatonpowersource.com/calculators/filtration/

Material gradient coefficients (MSK) for filter elements

The material gradient coefficients in psi/gpm apply to mineral oil (HLP) with a density of 0.876 kg/dm³ and a kinematic viscosity of 139 SUS (30 mm²/s). The pressure drop changes proportionally to the change in kinematic viscosity and density.

DTEF	VG					G			P
	3VG	6VG	10VG	16VG	25VG	25G	40G	80G	10P
625	0.643	0.446	0.286	0.249	0.170	0.0236	0.0220	0.0151	0.142

$\Delta p = f(Q)$ – characteristics according to ISO 3968

The pressure drop characteristics apply to mineral oil (HLP) with a density of 0.876 kg/dm³. The pressure drop changes proportionally to the density.

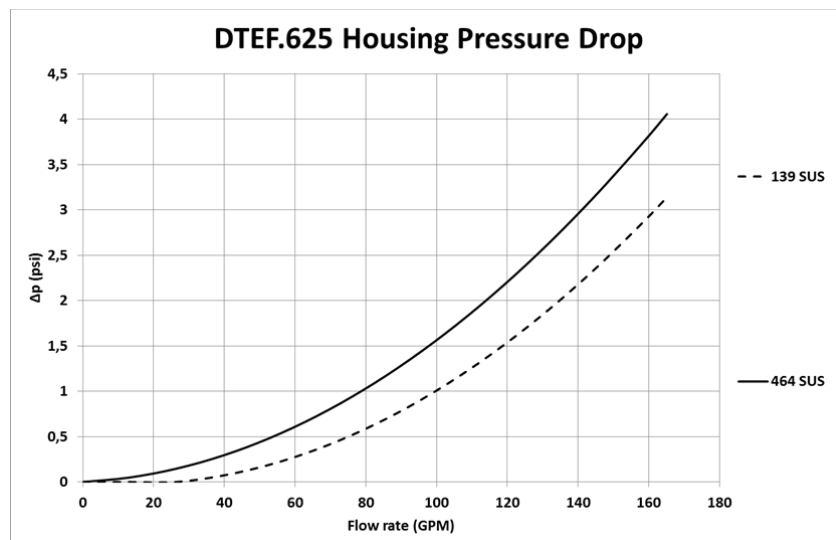

Symbols:

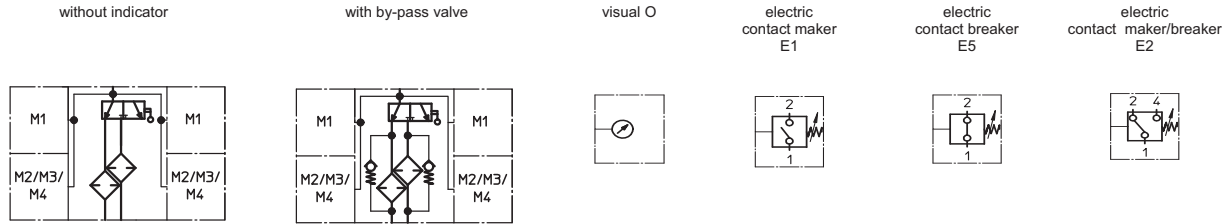

Spare parts:

item	qty.	designation	dimension	article-no.	
1	2	filter element	01.E631...		
2	2	filter head		316414	
3	2	filter cover	32571-4		
4	2	filter bowl without discharge pipe		316416	
	2	filter bowl with discharge pipe			
5	2	O-ring	140 x 3	304604 (NBR)	307514 (FPM)
6	2	O-ring	120 x 4	305300 (NBR)	307991 (FPM)
7	2	O-ring	63 x 3,5	311189 (NBR)	311592 (FPM)
8	2	O-ring	135 x 3,5	318386 (NBR)	318387 (FPM)
9	1	O-ring	56,75 x 3,53	306035 (NBR)	310264 (FPM)
10	1	O-ring	75 x 3	302215 (NBR)	304729 (FPM)
11	2	O-ring	18 x 3	304359 (NBR)	304399 (FPM)
12	2	screw plug	¼ BSPP	305003	
13	1	pressure switch, electric	alternatively E1, E2 or E5	see sheet-no. 1616	
14	1	clogging indicator, visual	O	see sheet-no. 1616	

Test methods:

Filter elements are tested according to the following ISO standards:

ISO 2941	Verification of collapse/burst resistance
ISO 2942	Verification of fabrication integrity
ISO 2943	Verification of material compatibility with fluids
ISO 3723	Method for end load test
ISO 3724	Verification of flow fatigue characteristics
ISO 3968	Evaluation of pressure drop versus flow characteristics
ISO 16889	Multi-pass method for evaluating filtration performance

North America
44 Apple Street
Tinton Falls, NJ 07724
Toll Free: 800 656-3344
(North America only)
Tel: +1 732 212-4700

Europe/Africa/Middle East
Auf der Heide 2
53947 Nettersheim, Germany
Tel: +49 2486 809-0

Friedensstraße 41
68804 Altlußheim, Germany
Tel: +49 6205 2094-0

An den Nahewiesen 24
55450 Langenlonsheim, Germany
Tel: +49 6704 204-0

China
No. 3, Lane 280,
Linhong Road
Changning District, 200335
Shanghai, P.R. China
Tel: +86 21 5200-0099

Singapore
4 Loyang Lane #04-01/02
Singapore 508914
Tel: +65 6825-1668

Brazil
Av. Julia Gaioli, 474 – Bonsucesso
07251-500 – Guarulhos, Brazil
Tel: +55 11 2465-8822

**For more information, please
email us at filtration@eaton.com
or visit www.eaton.com/filtration**

© 2015 Eaton. All rights reserved. All trademarks and registered trademarks are the property of their respective owners. All information and recommendations appearing in this brochure concerning the use of products described herein are based on tests believed to be reliable. However, it is the user's responsibility to determine the suitability for his own use of such products. Since the actual use by others is beyond our control, no guarantee, expressed or implied, is made by Eaton as to the effects of such use or the results to be obtained. Eaton assumes no liability arising out of the use by others of such products. Nor is the information herein to be construed as absolutely complete, since additional information may be necessary or desirable when particular or exceptional conditions or circumstances exist or because of applicable laws or government regulations.

Series DTEF 952

145 PSI

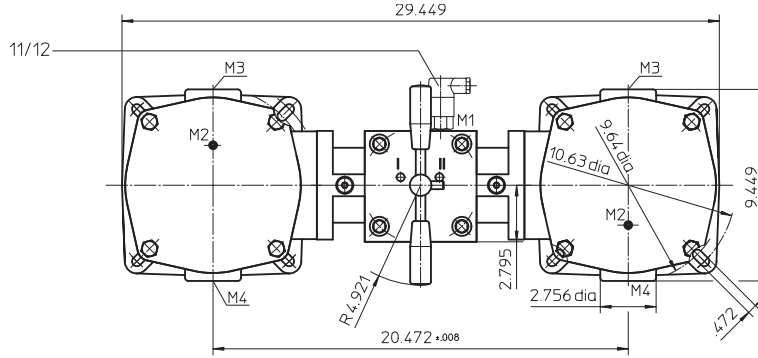

1) min. for element change without discharge pipe 21.88
 min. for element change with discharge pipe 30.70

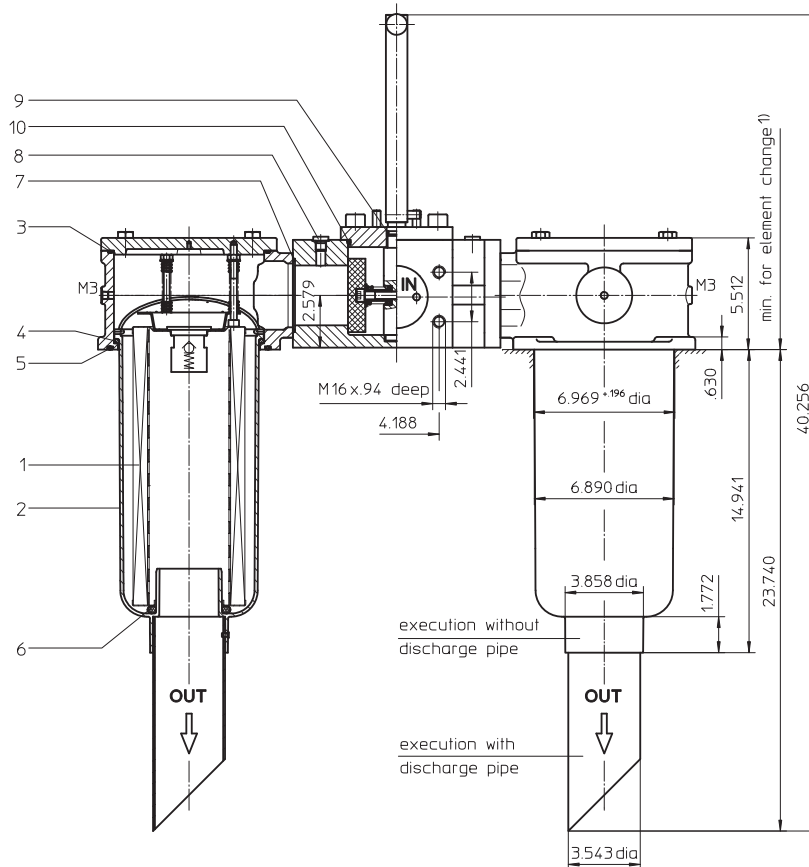

Position I: left filter-side in operation
 Position II: right filter-side in operation

Weight: approx. 119 lbs.

Dimensions: inches

Designs and performance values are subject to change.

Return Line Filter Series DTEF 952 145 PSI

Description:

Return-line filter series DTEF 952 have a working pressure up to 145 PSI.

The DTEF-filters are directly mounted to the reservoir and connected to the return-line.

A rotary slide valve which is integrated in the middle of the housing makes it possible to switch from the dirty filter-side to the clean filter-side without interrupting operation. These filters can be installed as suction filters.

The filter element consists of star-shaped, pleated filter material, which is supported on the inside by a perforated core tube and is bonded to the end caps with a high-quality adhesive. The flow direction is from outside to inside.

Eaton filter elements are known for a high intrinsic stability and an excellent filtration capability, a high dirt-retaining capacity and a long service life.

For filtration finer than 40 µm use the disposable elements made of microglass. Filter elements as fine as 5 µm(c) are available; finer filter elements on request.

Eaton filter elements can be used for petroleum-based fluids, HW emulsions, water glycols, most synthetic fluids and lubrication fluids. Consult factory for specific fluid applications.

When changing the filter element, a detachable connection between the filter head and the filter bowl prevents dirty oil from flowing into the tank.

1. Type index:

1.1. Complete filter: (ordering example)

DTEF.	952.	10VG.	10.	S.	P.	-.	FS.	A.	-.	E2.	-.	-.	-.	-.
1	2	3	4	5	6	7	8	9	10	11	12	13	14	15

- 1 series:**
DTEF = tank-mounted return-line-filter, change over
- 2 nominal size:** 952
- 3 filter-material and filter-fineness:**
80G, 40G, 25G stainless steel wire mesh
25VG, 16VG, 10VG, 6VG, 3VG microglass
10P paper
- 4 filter element collapse rating:**
10 = Δp 145 PSI
- 5 filter element design:**
E = without by-pass valve
S = with by-pass valve Δp 29 PSI
- 6 sealing material:**
P = Nitrile (NBR)
V = Viton (FPM)
- 7 filter element specification: (see catalog)**
- = standard
VA = stainless steel
IS06 = for HFC application, see sheet-no. 31601
- 8 process connection:**
FS = SAE-flange 3000 PSI
- 9 process connection size:**
A = 3"
- 10 filter housing specification: (see catalog)**
- = standard
IS06 = for HFC application, see sheet-no. 31605
- 11 clogging indicator at M1:**
- = without
O = visual, see sheet-no. 1616
E1 = pressure switch, see sheet-no. 1616
E2 = pressure switch, see sheet-no. 1616
E5 = pressure switch, see sheet-no. 1616
- 12 clogging indicator at M2:**
possible indicators see position 11 of the type index
- 13 clogging indicator at M3:**
possible indicators see position 11 of the type index
- 14 clogging indicator at M4:**
possible indicators see position 11 of the type index
- 15 discharge pipe:**
- = without
1 = with discharge pipe

To add an indicator to your filter, use the corresponding indicator data sheet to find the indicator details and add them to the filter assembly model code.

1.2. Filter element: (ordering example)

01E.	950.	10VG.	10.	S.	P.	-.
1	2	3	4	5	6	7

- 1 series:**
01E. = filter element according to company standard
- 2 nominal size:** 950
- 3 - 7** | see type index-complete filter

Technical data:

design temperature:	14 °F to +212 °F
operating temperature:	14 °F to +176 °F
operating medium	mineral oil, other media on request
max. operating pressure:	145 PSI
opening pressure by-pass valve:	29 PSI
process connection:	SAE-flange 3000 PSI
housing material standard:	Al, glass fiber reinforced polyamide
sealing material:	Nitrile (NBR) or Viton (FPM), other materials on request
installation position:	vertical
volume tank:	2x 2.6 Gal.

Classified under the Pressure Equipment Directive 2014/68/EC for mineral oil (fluid group 2), Article 4, Para. 3.
Classified under ATEX Directive 2014/34/EC according to specific application (see questionnaire sheet-no. 34279-4).

Pressure drop flow curves:

Filter calculation/sizing

The pressure drop of the assembly at a given flow rate Q is the sum of the housing Δp and the element Δp and is calculated as follows:

$$\Delta p_{assembly} = \Delta p_{housing} + \Delta p_{element}$$

$$\Delta p_{housing} = (\text{see } \Delta p = f(Q) \text{ - characteristics})$$

$$\Delta p_{element} (PSI) = Q (GPM) \times \frac{MSK}{1000} \left(\frac{PSI}{GPM} \right) \times \nu (SUS) \times \frac{\rho}{0.876} \left(\frac{kg}{dm^3} \right)$$

For ease of calculation our Filter Selection tool is available online at www.eatonpowersource.com/calculators/filtration/

Material gradient coefficients (MSK) for filter elements

The material gradient coefficients in psi/gpm apply to mineral oil (HLP) with a density of 0.876 kg/dm³ and a kinematic viscosity of 139 SUS (30 mm²/s). The pressure drop changes proportionally to the change in kinematic viscosity and density.

DTEF	VG					G			P
	3VG	6VG	10VG	16VG	25VG	25G	40G	80G	10P
952	0.364	0.253	0.162	0.141	0.096	0.0179	0.0167	0.0115	0.076

$\Delta p = f(Q)$ – characteristics according to ISO 3968

The pressure drop characteristics apply to mineral oil (HLP) with a density of 0.876 kg/dm³. The pressure drop changes proportionally to the density.

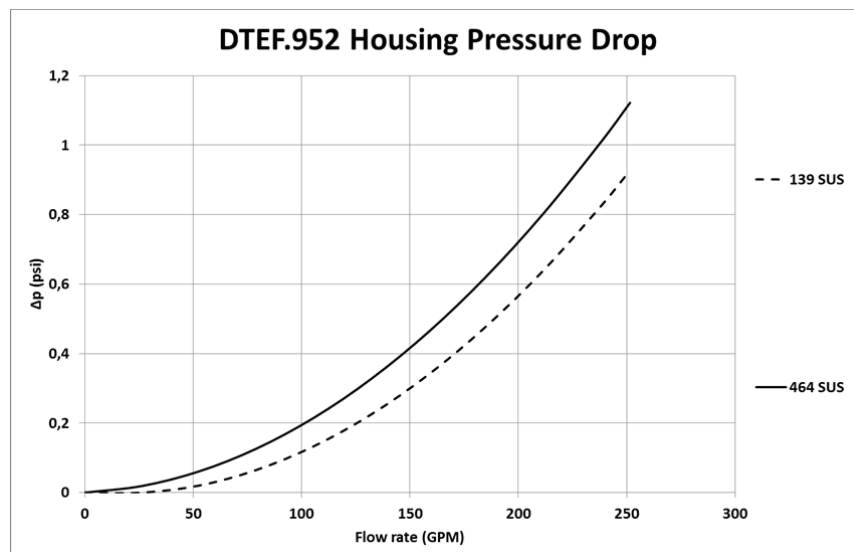

Symbols:

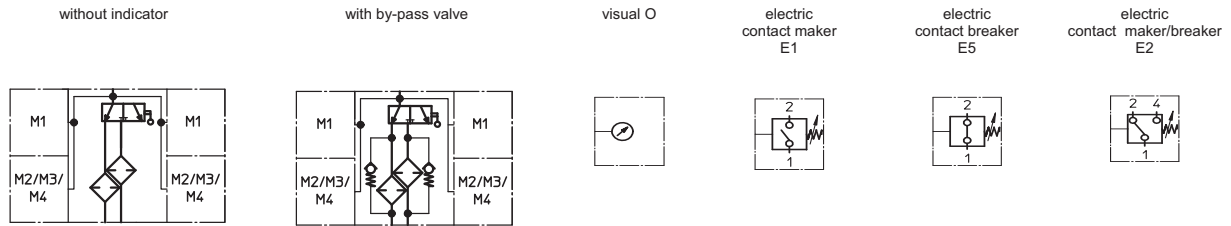

Spare parts:

item	qty.	designation	dimension	article-no.	
1	2	filter element	01.E950...		
2	2	filter bowl without discharge pipe		327460	
	2	filter bowl with discharge pipe		327461	
3	2	O-ring	195 x 3,5	301831 (NBR)	306528 (FPM)
4	2	O-ring	170 x 6	304799 (NBR)	306529 (FPM)
5	2	O-ring	190 x 5	305432 (NBR)	310283 (FPM)
6	2	O-ring	78 x 10	305017 (NBR)	305552 (FPM)
7	2	O-ring	85,32 x 3,53	305590 (NBR)	306308 (FPM)
8	2	screw plug	¼ BSPP	305003	
90	1	O-ring	18 x 3	304359 (NBR)	304399 (FPM)
10	1	O-ring	105 x 5	310003 (NBR)	323080 (FPM)
11	1	pressure switch, electric	alternatively E1, E2 or E5	see sheet-no. 1616	
12	1	clogging indicator, visual	O	see sheet-no. 1616	

Test methods:

Filter elements are tested according to the following ISO standards:

ISO 2941	Verification of collapse/burst resistance
ISO 2942	Verification of fabrication integrity
ISO 2943	Verification of material compatibility with fluids
ISO 3723	Method for end load test
ISO 3724	Verification of flow fatigue characteristics
ISO 3968	Evaluation of pressure drop versus flow characteristics
ISO 16889	Multi-pass method for evaluating filtration performance

North America

44 Apple Street
Tinton Falls, NJ 07724
Toll Free: 800 656-3344
(North America only)
Tel: +1 732 212-4700

Europe/Africa/Middle East

Auf der Heide 2
53947 Nettersheim, Germany
Tel: +49 2486 809-0

Friedensstraße 41
68804 Altlufsheim, Germany
Tel: +49 6205 2094-0

An den Nahewiesen 24
55450 Langenlonsheim, Germany
Tel: +49 6704 204-0

China

No. 3, Lane 280,
Linhong Road
Changning District, 200335
Shanghai, P.R. China
Tel: +86 21 5200-0099

Singapore

4 Loyang Lane #04-01/02
Singapore 508914
Tel: +65 6825-1668

Brazil

Av. Julia Gaioli, 474 – Bonsucesso
07251-500 – Guarulhos, Brazil
Tel: +55 11 2465-8822

For more information, please

email us at filtration@eaton.com
or visit www.eaton.com/filtration

© 2015 Eaton. All rights reserved. All trademarks and registered trademarks are the property of their respective owners. All information and recommendations appearing in this brochure concerning the use of products described herein are based on tests believed to be reliable. However, it is the user's responsibility to determine the suitability for his own use of such products. Since the actual use by others is beyond our control, no guarantee, expressed or implied, is made by Eaton as to the effects of such use or the results to be obtained. Eaton assumes no liability arising out of the use by others of such products. Nor is the information herein to be construed as absolutely complete, since additional information may be necessary or desirable when particular or exceptional conditions or circumstances exist or because of applicable laws or government regulations.